



# M274QZ

**7" Digital LCD Quad Monitor**

**Installation & User Manual**



- ⚠ **Important - Please read this manual before installing**
- ⚠ **Objects viewed in monitor are closer than they appear.**

The M274QZ Monitor is not intended to replace any of your vehicles mirrors or other safety devices. It is not a substitute for proper defensive driving techniques. Please obey all traffic laws and motor vehicle safety regulations.

Do Not Open Monitor Housing. There are no parts that can be serviced.

**Opening Monitor Housing Will Void Your Warranty**

Red Power Wire must be connected to accessory that is turned off when key is removed from vehicle to prevent power draw.

## FEATURES

The M274QZ monitor is designed for the commercial trucking industry. It is built to withstand the shock and vibration associated with industrial applications.

- Designed with Heavy Duty
- Resolution: 1,152,000 Pixels (800\*3(RGB)\*480)
- Support 5 Cameras Input (W A/V Input)
- Passed J1455 Requirements
- Supports 20G Vibration Rating
- Supports IP 65 Waterproof / Dustproof
- Supports Quad/Triple/Single Split Screen Mode
- Adjustable On Screen Distance Marker
- Support Dimmer Feature For Night Viewing
- Support Digital Zoom
- Support 8 Languages
- Normal/Mirror Mode Support
- Red Icon Blinking On Screen When Vehicle Gear Switches to Reverse Mode
- Support AUX A/V Input & Output
- Supports Camera Scanning When Power On
- 10 48V DC Free Voltage Operation

## MONITOR SPECIFICATIONS

TV System	NTSC / PAL
LCD Panel	7" Digital LCD Color Monitor With OSD Function
Display Size	156.5 (W) x 89 (H)
Field of View	Top: 40°, Bottom: 60°, Left: 60°, Right: 60°
Resolution	800 x 3 (RGB) x 480
Picture Image	Factory Preset To Reverse Image
Power Connector	Red: Positive 10V ~ 48V Input
	Black: Ground
	Green: Reverse Gear 10V ~ 48V Input
	White: 10V ~ 48V Input
	Blue: 10V ~ 48V Input
Inputs	Brown: 10V ~ 48V Input
	RCA / 4 Pin Multi Connector
	12V, 0.2A DC (Output)
	Audio Input
	Heater
Accessories	Video Input: 1.0V p-p, 75ohm, Sync Negative
	Ground (Chassis)
	Sunvisor
	Monitor Bracket
	Screw Kits

# MONITOR CONTROLS

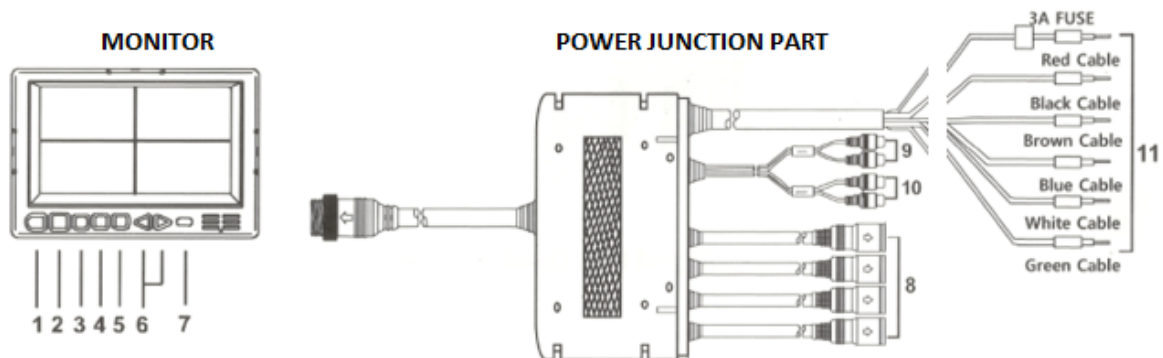

## 1. POWER/MENU

### Power

- Press the power/menu button to turn the screen ON (Switch Red to Green Lamp)
- Press the power/menu button to turn the screen OFF

### Menu

- Press the power/menu button to enter the MENU mode
- Press the power/menu button 5 times to enter the FUNCTION, PICTURE, NON/MIR, UP/DOWN TRIGGER, CAMERA NAME, CAM NODES, SCAN, REAR SCALE ADJ

## 2. QUAD(PIP) SELECT

Press the QUAD(PIP) button to enter the QUAD

- 3 PIP (CA1 LARGE, CA3/4/2 SMALL), 2 PIP (CA1 LARGE, CA3/2 SMALL)
- 3 SPLIT (CA1/2/3) → 2 SPLIT (CA3/2) → 2 SPLIT (CA4/1) → QUAD

## 3. AUTO SCAN & LOCKING

- Press the scan button, it shows the CA1 → CA2 → CA3 → CA4
- Press the lock button for 3 seconds → "BUTTONS HAVE BEEN LOCKED!"
- Press the lock button for 3 seconds to unlock → "BUTTONS HAVE BEEN UNLOCKED!"

## 4. CAMERA SELECT

- Press the camera button one by one, it shows CA1 → CA2 → CA3 → CA4

## 5. ZOOM & AV SELECT

- Press the zoom button in single channel full screen mode

## 6. VOLUME CONTROL

- Press the ► button for volume up and the ◀ for volume down

## 7. DIMMER CONTROL

- Default is the brightest mode
- User can set the LCD Backlight Brightness. Monitor brightness automatically change as set

## 8. CAMERA INPUT CONNECTOR

- Four mini din type connectors or the camera inputs
- Connect the cameras to the monitor power junction part camera input that supplied
- Monitor delivers the power to the camera through the supplied power junction part



Pin Number	Description
1	Video
2	Audio
3	DC 12V Power (CA1 Switching)
4	Ground
5	Heater B+

## 9. A/V INPUT CONNECT

- Connect A/V input to the second camera or an external device with the RCA type output

## 10. A/V OUTPUT CONNECT

- Connect A/V output to the second monitor or an external device with RCA type input

## MONITOR CONTROLS CONTINUED...

### 11. POWER CABLE







- Connect the red wire the (DC 10 ~ 48V) positive + power terminal which is energized with the ignition key in the accessory position
- Connect the black wire to the metal surface on the car or place on a negative battery
- Connect the green wire to the switched positive + power output terminal of the "R" gear
- Connect the white wire to the switched positive + power output terminal of CA2
- Connect the blue wire to the switched positive + power output terminal of CA3
- Connect the brown wire to the switched positive + power output terminal of CA4

Cable Color	Description
Red	Positive Power (DC 10V ~ 48V)
Black	Ground
Green	"R" Gear Power (DC 10V ~ 48V)
White	Positive Power (DC 10V ~ 48V)
Blue	Positive Power (DC 10V ~ 48V)
Brown	Positive Power (DC 10V ~ 48V)



## MONITOR MENU

- Select  menu button to enter or exit the monitor menu
- Monitor will switch to main screen while no key input in 10 seconds
- Main Menu Title: FUNCTION, PICTURE, NOR/MIR, UP/DOWN, TRIGGER, CAMERA NAME, CAM MODES, SCAN

### 1. OPERATE

- From menu to menu:  Previous Menu,  Following Menu
- Sub menu selection:  Enter the sub menu from the menu
- From sub menu to sub menu:  Up,  Down
- Sub menu selection:  or 

## MENU TREE

FUNCTION		DESCRIPTION	TRIGGER		DESCRIPTION
LANGUAGE	ENGLISH	8 LANGUAGES	REAR SCALE	ON	OFF
SYSTEM	NTSC/PAL	TV SYSTEM	BLINK MARK	ON	OFF
DIRECTION	0° / 180°	ANGLE	TRIG 1	CAM1	
DIMMER	1(2,3,4,5,OFF)	SET BRIGHTNESS	TRIG 2	CAM3/CAM2	
AUTO POWER	ON		TRIG 3	2 PIP	
LOGO SET		ON, (2-20 secs)	TRIG 4	3 PIP	
AV OUTPUT	LIVE/QUAD		HAZARD	QUAD	
SHUTTER	ON		<b>CAMERA NAME</b>		<b>DESCRIPTION</b>
RESET		FACTORY DEFAULT	CAM1	REAR	
<b>PICTURE</b>		<b>DESCRIPTION</b>	CAM2	RIGHT	
CONTRAST	15		CAM3	LEFT	
BRIGHTNESS	15		CAM4	FRONT	
COLOR	15		<b>CAM MODES</b>		<b>DESCRIPTION</b>
TINT	15		QUAD	ON	OFF
<b>NOR/MIR</b>		<b>DESCRIPTION</b>	3 PIP	ON	OFF
CAM1	NORMAL	MIRROR	2 PIP	ON	OFF
CAM2	NORMAL	MIRROR	3 SPLIT	ON	OFF
CAM3	NORMAL	MIRROR	CAM3/2 SPLIT	ON	OFF
CAM4	NORMAL	MIRROR	CAM4/1 SPLIT	ON	OFF
ALL	NORMAL	MIRROR	<b>SCAN</b>		<b>DESCRIPTION</b>
<b>UP/DOWN</b>		<b>DESCRIPTION</b>	AUTO SCAN	ON	
CAM1	UP/DOWN	UP SIDE DOWN	SCAN KEY	ONE	FULL
CAM2	UP/DOWN	DOWN SIDE UP	CAM1	3	(SEQUENCE)
CAM3	UP/DOWN		CAM2	3	
CAM4	UP/DOWN		CAM3	3	
ALL	UP/DOWN		CAM4	3	
<b>REAR SCALE ADJ</b>					
-----					
<b>STOP</b>				<b>REAR</b>	

## SCREEN DISPLAY

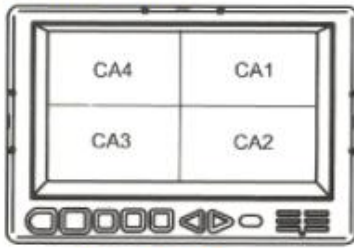

QUAD DISPLAY

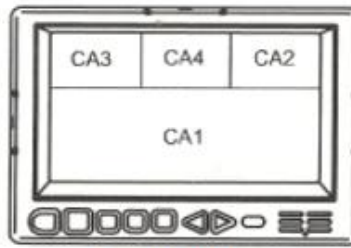

3 PIP DISPLAY

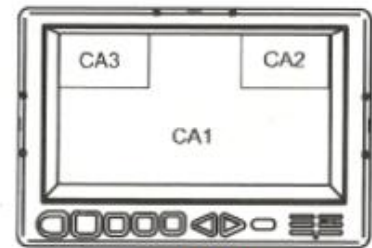

2 PIP DISPLAY

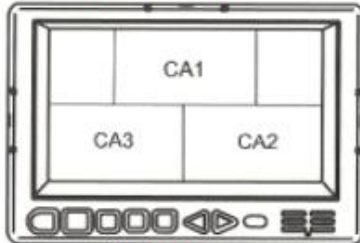

3 SPLIT DISPLAY

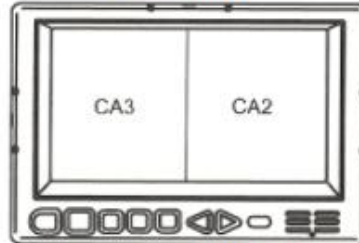

2 SPLIT DISPLAY (CA3/CA2)

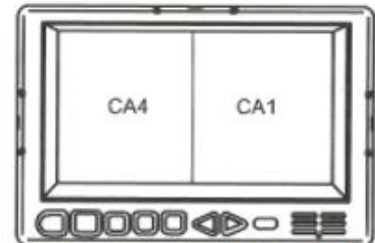

2 SPLIT DISPLAY (CA4/CA1)

## TRIGGER DISPLAY

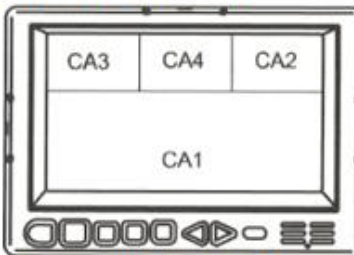

TRIGGER 3 PIP DISPLAY

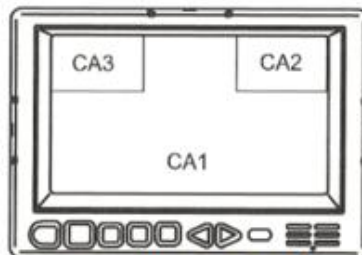

TRIGGER 2 PIP DISPLAY

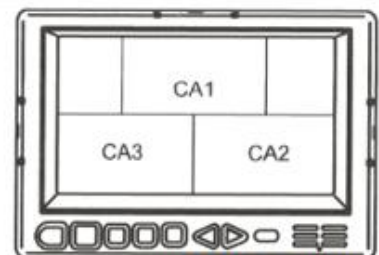

TRIGGER 3 SPLIT DISPLAY

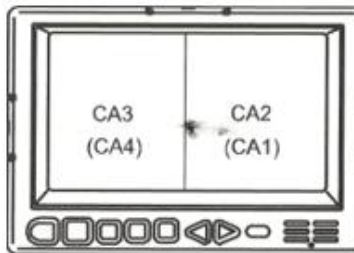

TRIGGER 2 SPLIT DISPLAY

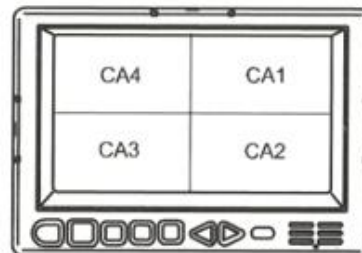

TRIGGER QUAD DISPLAY



TRIGGER SINGLE DISPLAY

## CONNECTION

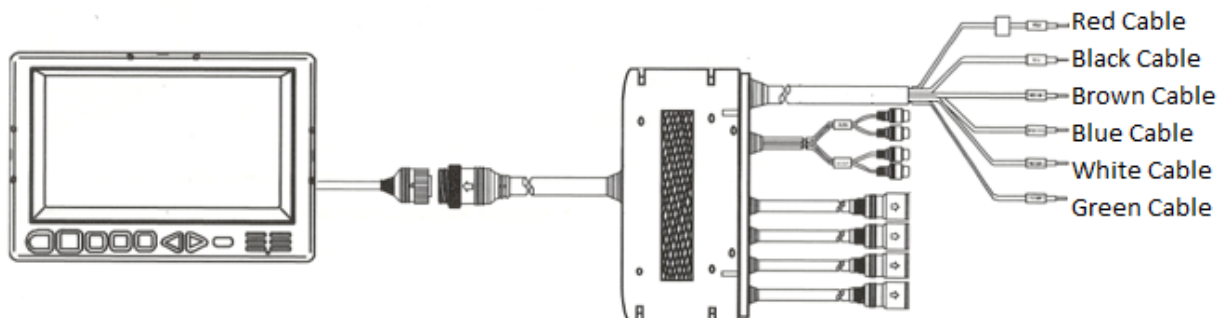

## CONNECTION CONTINUED...

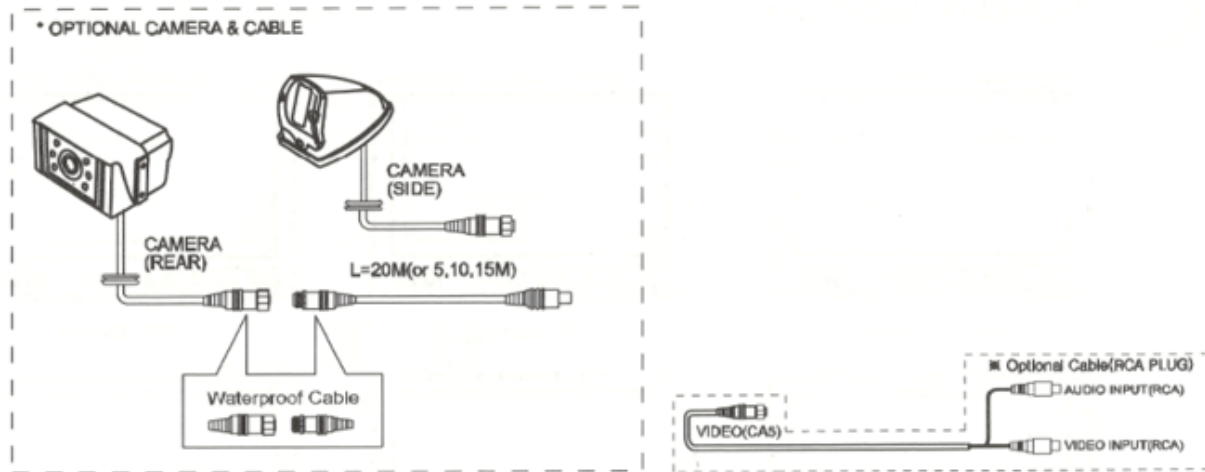

- Connect the red wire the (DC 10 ~ 48V) positive + power terminal which is energized with the ignition key in the accessory position
- Connect the black wire to the metal surface on the car or place on a negative battery
- Connect the green wire to the switched positive + power output terminal of the "R" gear
- Connect the white wire to the switched positive + power output terminal of the trigger input
- Connect the blue wire to the switched positive + power output terminal of the trigger input
- Connect the brown wire to the switched positive + power output terminal of the trigger input

- ⚠ Before making the connection, disconnect the ground terminal of the car battery to avoid short circuiting
- ⚠ The plugs should be fully inserted into the connectors or jacks. A loose connection may cause malfunction.

## MONITOR INSTALLATION

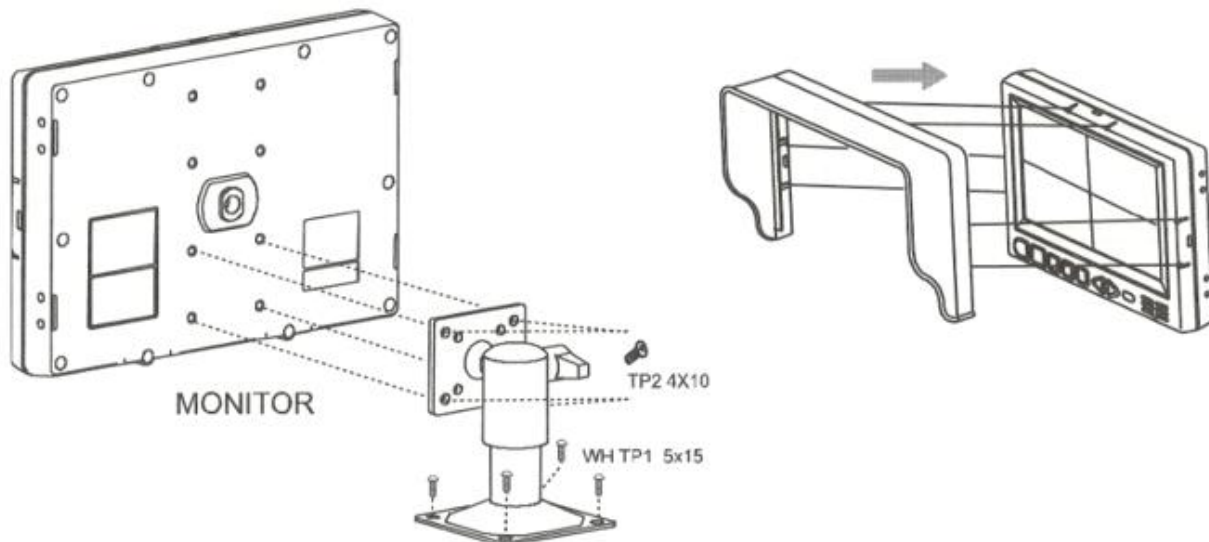

- ▶ Before installing the monitor, clean it with alcohol
- ▶ Attach the supplied bracket on the back of monitor
- ▶ Fix between the monitor and bracket with supplied fixing screws
- ▶ Adjust the angle and direction for proper viewing on the monitor
- ▶ Connect the wires accordingly
- ▶ Attach the sunvisor to the monitor if needed
- ▶ Remove the sunvisor from the monitor when not needed

## **OPERATING INSTRUCTIONS**

- When the user turns the ignition key to the Accessory or ON position, the power will supply to the monitor and the monitor will be in display mode.
- In case the monitor is turned off, when you set the gear lever to the Reverse position, the monitor will turn on and the picture will display from the CA1

## **CLEANING AND GENERAL MAINTENANCE**

- Cool off the inside of vehicle when the temperature is high from long term direct sunlight
- Clean the unit with a slightly damp soft cloth. Use mild household detergent.
- Never use strong solvents such as thinner or benzine as they may cause damage to the unit
- Do not attempt to service this system, it may expose to dangerous voltage or other hazards
- Refer all servicing to qualified service personnel

### **[FCC COMPLIANCE STATEMENT]**

- This equipment has been tested and found to comply with limits for a Class A digital device, pursuant to part 15 of the FCC rules.
- These limits are designed to provide reasonable protection against harmful interference when the equipment is operated in a commercial environment.
- This equipment generates, uses, and can radiate radio frequency energy and, if not installed and used in accordance with the manual, may cause harmful interference to radio communications
- Operation of this equipment in a residential area is likely to cause harmful interference in which case the user will be required to correct the interference at their own expense.

 Any changes or modifications in construction of this device which are not expressly approved by the party responsible for compliance could void the user authority to operate the equipment

