



# M3104QHD

## 10" HD Digital LCD Color Monitor

### Installation & User Manual



Please read all instructions before using the product, and keep the manual for future reference. The product may differ from the manual description according to upgrades. S/W version or performance, may be altered without notice.

## FEATURES

- HD 10" Monitor
- Waterproof IP66
- Supports SSD/Micro SD Recording
- Supports Multiple Resolutions
- Touchscreen
- Multiple Video Formats Available
- Anti-glare film for monitor screen

## SPECIFICATIONS

LCD Size	10"
Resolution	1024 x 600 (RGB)
Brightness	650 cd/m <sup>2</sup>
Cameras	4
Viewing Angle	U: 85° / D: 85°, R/L: 85°
Triggers	5
Operating Temperature	-20 ~ +70°C, RH 90%
Storage Temperature	-30 ~ +80°C, RH 90%
Power Consumption	Max 32W
Input Voltage	10-32V
Video Inputs	4-Channel Camera Input
Audio Inputs	4
Storage	2-Micro SD (512G) + 1-SSD (2TB)
Contrast	700:1
Loudspeaker	1W/8Ω
Split Screen	Yes

## ACCESSORIES



U-Support Bracket



Remote Control



Sun Shield



Angle Adjustment Screws



AV & Power Supply Cable

## PARTS IDENTIFICATION

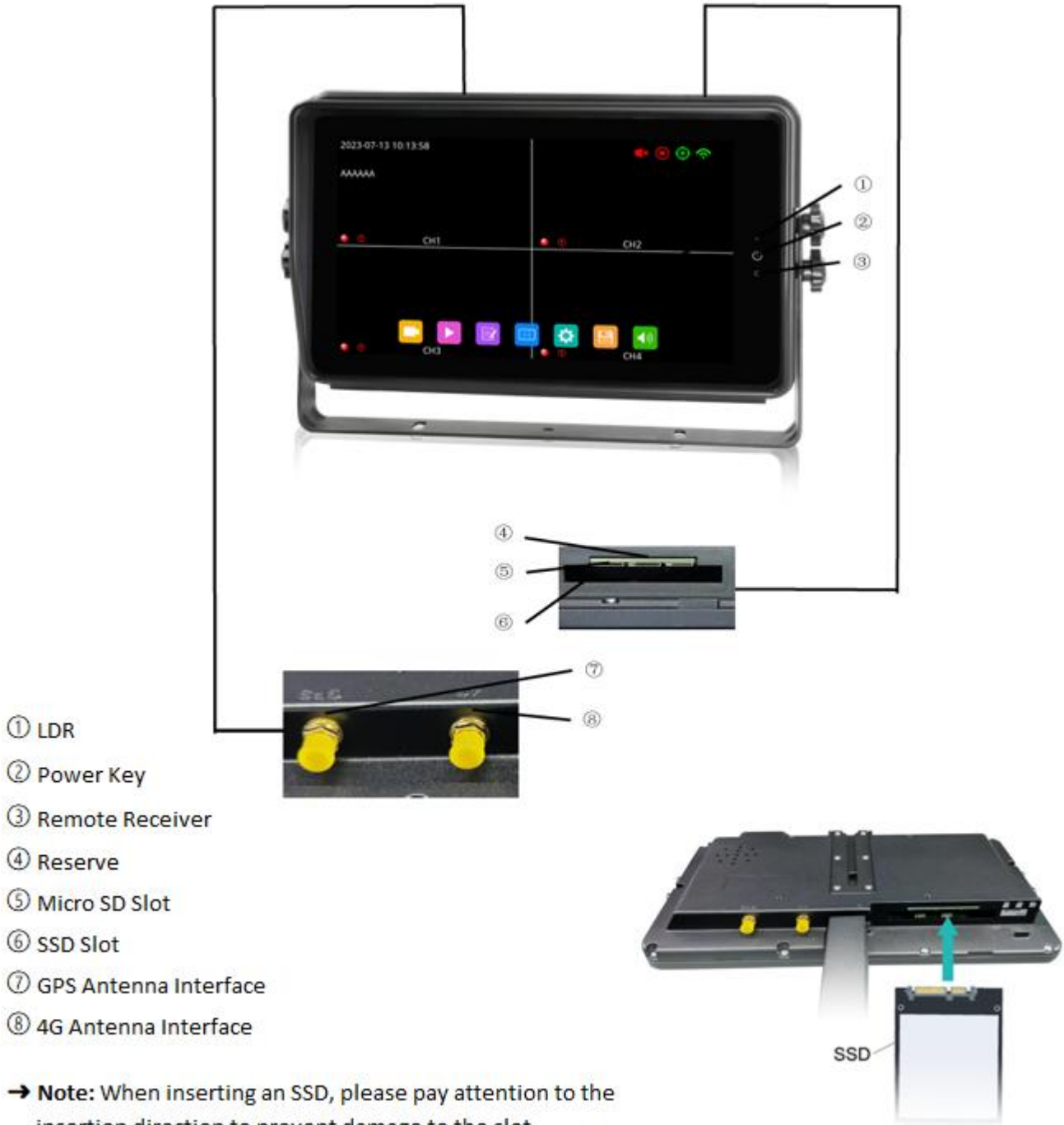

## CONNECTIONS

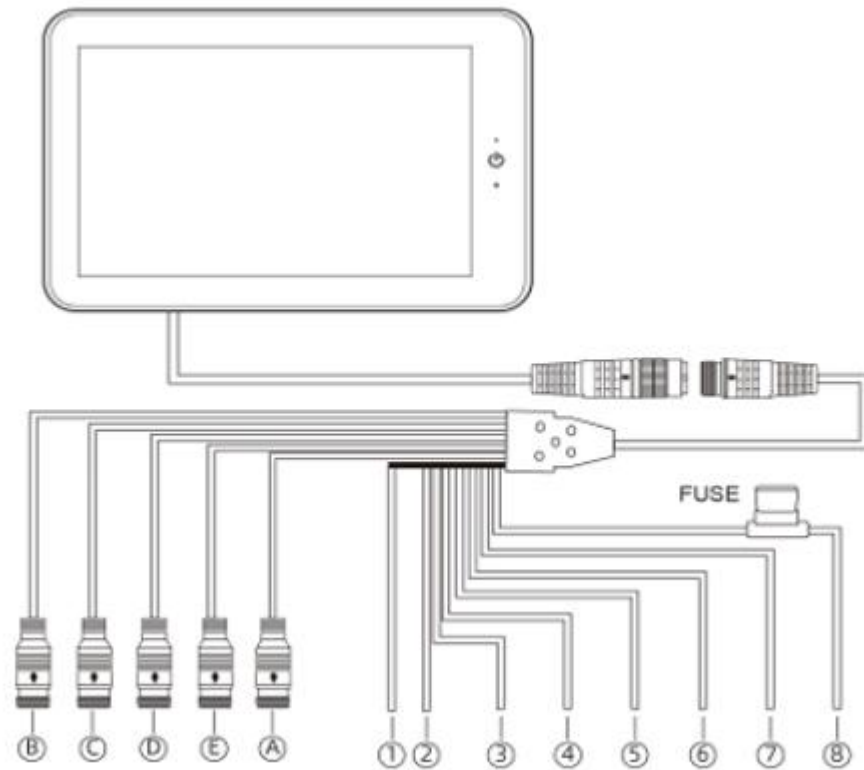

- Ⓐ Black 5P: USB Output, along with USB to CVBS conversion cable for CVBS output
- Ⓑ White 4P Male for Camera 1
- Ⓒ Blue 4P Male for Camera 2
- Ⓓ Green 4P Male for Camera 3
- Ⓔ Brown 4P Male for Camera 4

- ① Single white wire to positive power wire of Camera 1
- ② Single blue wire to positive power wire of Camera 2
- ③ Single green wire to positive power wire of Camera 3
- ④ Single brown wire to positive power wire of Camera 4
- ⑤ Single yellow wire to positive power wire of Camera Split
- ⑥ Single orange wire to vehicle ACC
- ⑦ Single black wire to GND
- ⑧ Single red wire to power wire of DC: 10-32V

## MENU OPERATION - REMOTE CONTROL

### 6.1 IR Remote Control

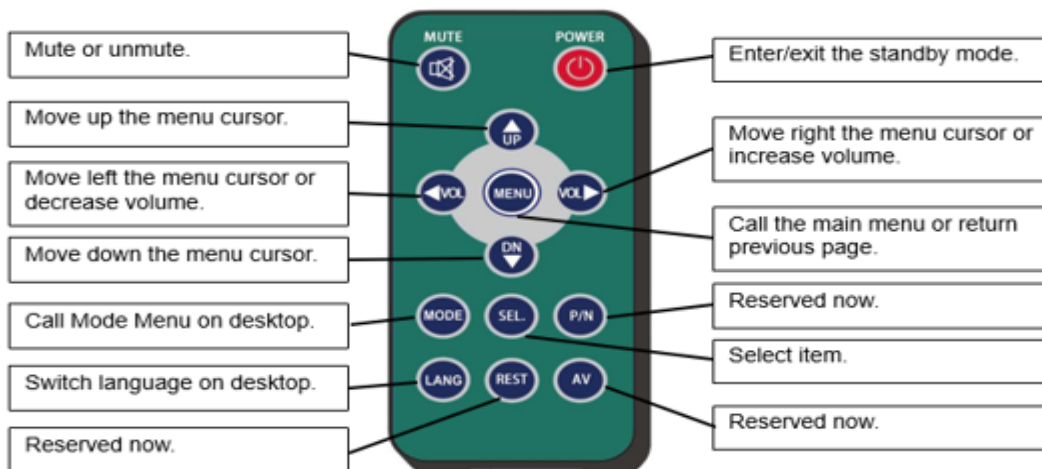

#### 1. MUTE

- Mute or unmute the monitor

#### 2. POWER

- Enter or exit the standby mode

#### 3. VOL ▷

- Open the volume adjustment menu
- Move the right menu cursor

#### 4. VOL ◁

- Open the volume adjustment menu
- Move the left menu cursor

#### 5. UP ▲

- Move the menu cursor up

#### 6. DOWN ▼

- Move the menu cursor down

#### 7. MENU

- Go to the main menu

#### 8. MODE

- Go to Mode Menu on desktop

#### 9. LANG

- Switch to different languages on desktop

#### 10. SEL

- Select item

## MENU OPERATION - TOUCHSCREEN FUNCTION

### 6.2 Touchscreen Function

► When the display shows a split mode and hides the menu, double clicking on one channel will switch to the single screen of that channel. Click again to return to the original split screen. Other menu operation, please refer to the corresponding sections.

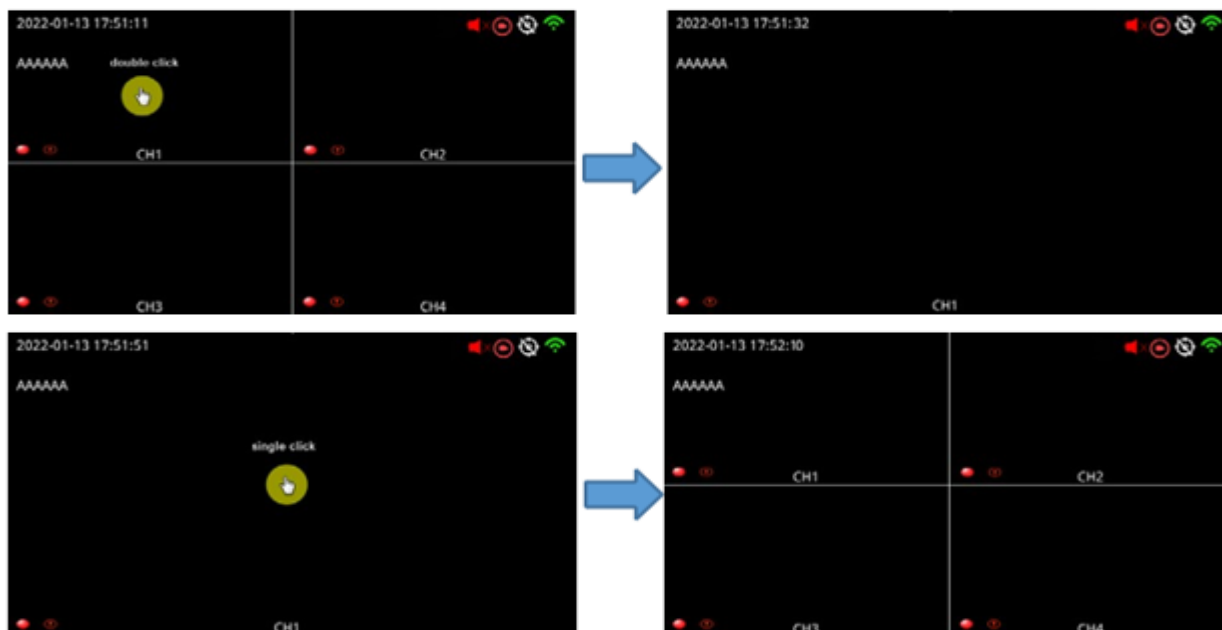

## MENU INTRODUCTION

### 7.1 Menu Introduction

► Before logging in, press the [MENU] button on the remote control or click on the bottom area of the touch screen, and the LCD screen will display the menu interface. To access the detail contents of the menu, you need to log in first. After logging in, you will have access to all configurations

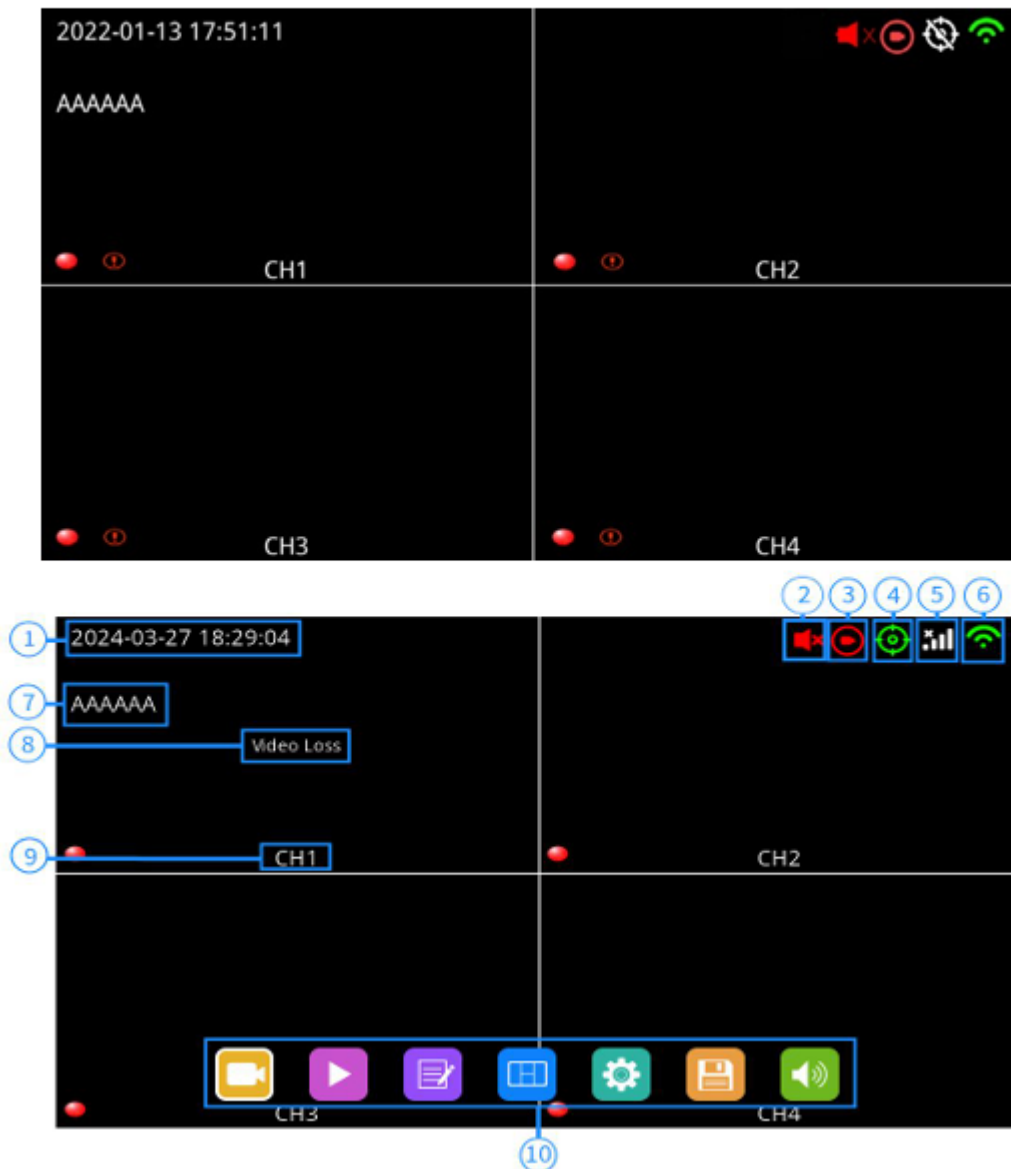

1. System time
2. Mute icon (appears when device is muted)
3. Record icon
4. GPS icon: flickers when connecting, long lit when connected
5. 2G/3G/4G
6. WLAN Icon
7. License Plate Number
8. Video Loss Warning
9. Channel Name
10. Menu zone: click to show the menu icon

# MENU LOCK

## 7.2 Menu Lock



- Two types of menu access: administrator access and guest access
- User permission list

	Administrator	Guest
<b>Username</b>	admin	guest
<b>Default Password</b>	123	321
<b>Menu Access</b>	all	Only play menu, display menu, and volume menu

- Username cannot be changed, but the password can. Guests do not have access to the settings menu, so password change is unavailable (For changing passwords, please refer to the following instructions)

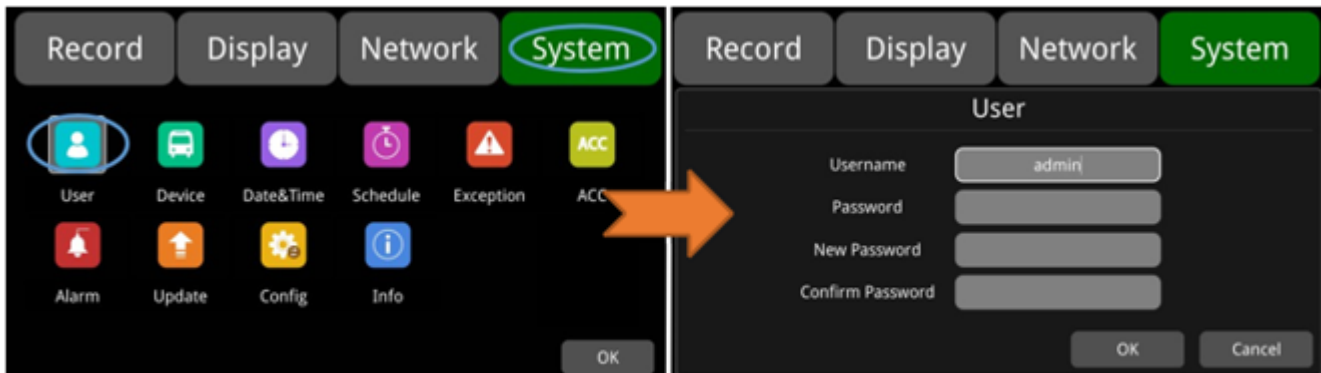

## MENU LOCK CONTINUED...

- User admin and password are required to change the menu lock status. Below figure shows how to change the menu lock status from "on" to "off"

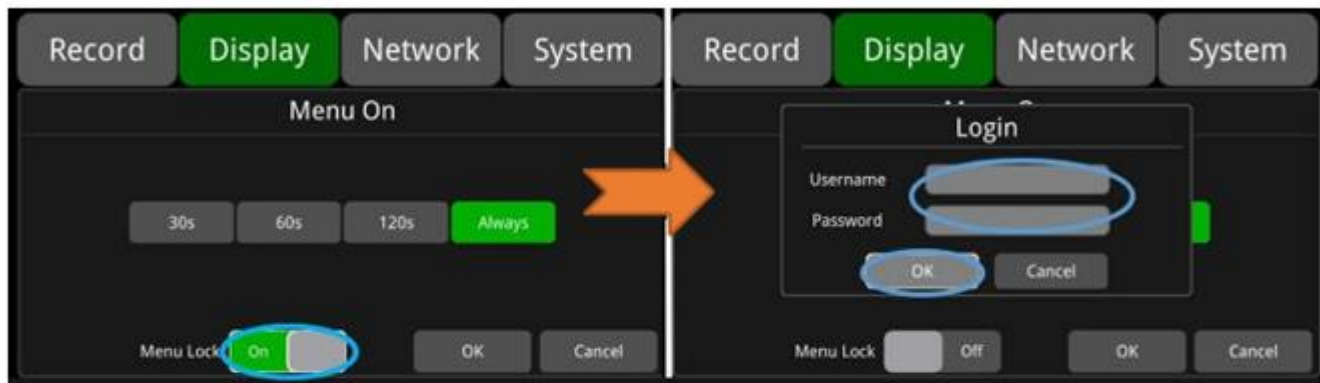





- ▶ When the menu lock status is "on", we need to enter the username admin and password to access the "Record", "Play", "Log", "Settings", "Disk" and other menus. Username guest and password will only allow access to the "Play" menu. "Layer switching" and "volume adjustment" are open without the need to input any information. When the menu lock status is "off", no username and password are needed to enter all menu setting

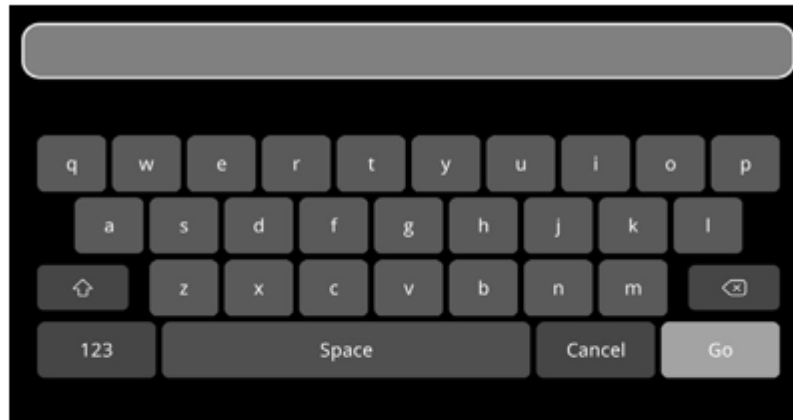

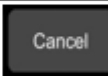

## KEYBOARD INSTRUCTIONS



	Uppercase / Lowercase Switch		Exit without saving configuration
	Exit after saving configuration		Delete input characters
	Switch to numbers		Switch to English
	Switch to special characters		

## SPECIAL KEYS

	<b>Manual Recording Button:</b> Click this button, or select it and then press the SEL button to close or open the recording
	<b>Video Playback Button:</b> Click this button, or select it and press the SEL button. The system will enter the recording calendar. The prompt dialog box will display "Unable to record in play-back mode! Continue?". Press "OK" to proceed. If the date mark in the calendar interface is green, it means there's video files or pictures saved on that day. Press this icon to enter the video/picture file list, select the video file or the picture want to check, and then press the "Play" button. You can select one or more videos/pictures at a time. Multiple videos/pictures can be played in sequence and can switch to the next or previous video/picture. The specific operation will be shown in the below.

# CALENDAR INTERFACE



Switch Months



Switch Years

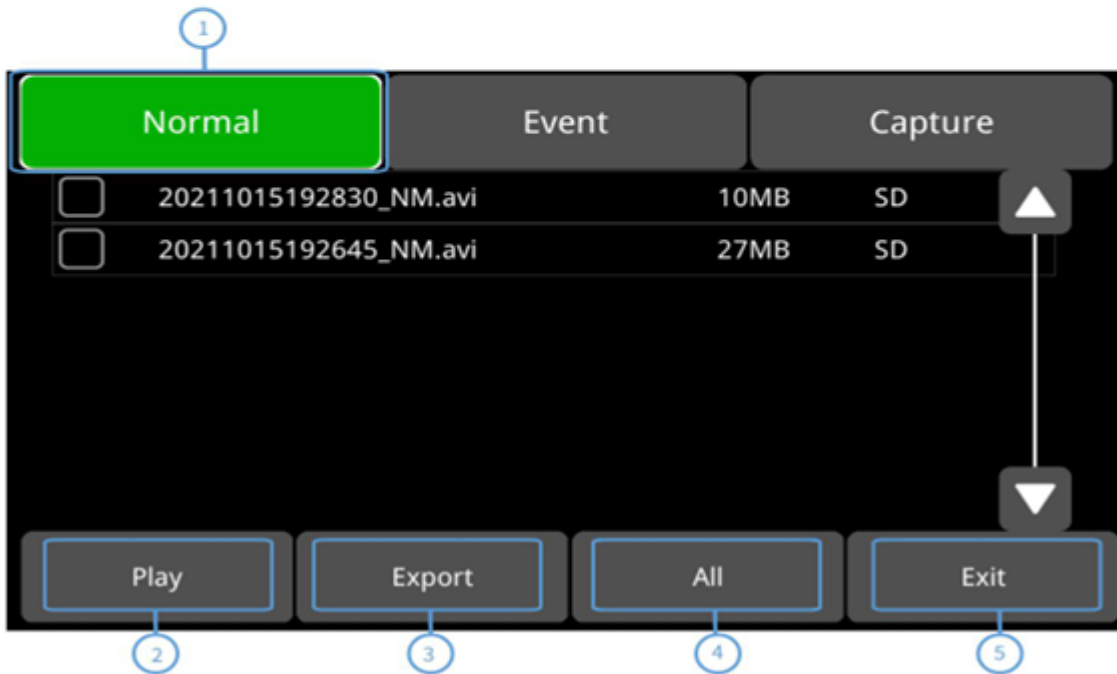

## CALENDAR INTERFACE CONTINUED...

### ► Recording List Interface (1)

- ① Two recording types: Normal and Event. Capture saved image for snapshot
- ② Play: Play selected video file
- ③ Export: Export the selected video file to USB (Currently not supported)
- ④ All: Select all files on that page
- ⑤ Exit: Exit the screen

### ► Recording List Interface (2)

- The file name contains abbreviation for the recording type, which can help identify the recording type

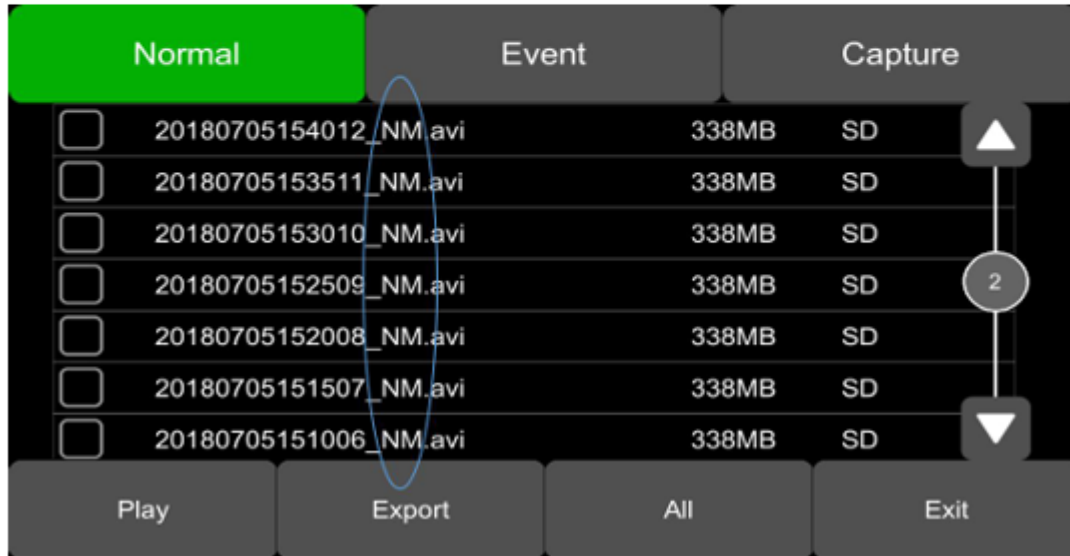

→ Abbreviations for the recording types are as follows:

NM	Normal recording	TI	Scheduled Recording
MO	Motion Detection Recording	SP	Speed Recording (the speed source is GPS)
TP	Temperature Recording	BT	Panic Button Recording
A1	Alarm 1 Recording	A2	Alarm 2 Recording
A3	Alarm 3 Recording	A4	Alarm 4 Recording
A5	Reverse Recording	A6	Brake Recording
PB	Pedestrian Detection Recording	CR	Collision Alarm Recording
SK	Lane Deviation Alarm Recording	OS	Over Speed Recording (the speed source is ADAS)
GS	G-Sensor Recording (Easy Mode)	ND	No Driver Alarm Recording
FT	Fatigue Alarm Recording	DS	Distraction Alarm Recording
CA	Phone Using Alarm Recording	SM	Smoking Alarm Recording

## PLAYBACK INTERFACE

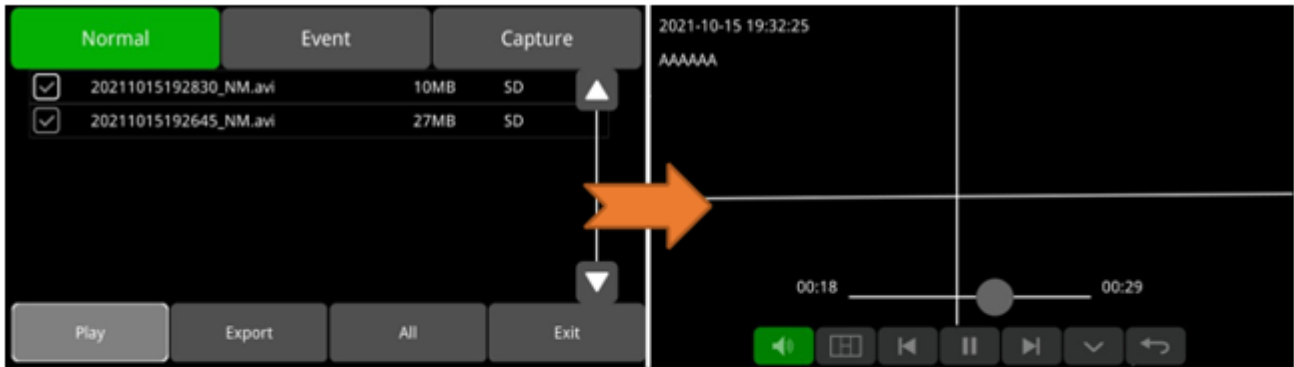

	Volume adjust button
	Click the video playback split mode button to switch the split screen to single screen or single screen to segmentation mode
	Play the previous or the next video
	Pause or resume playback
	Click to hide or show the playback menu
	Exit Playback

## LOG



**System Log Button:** Click this button, or select it and press SEL to enter the log interface to query or export system logs

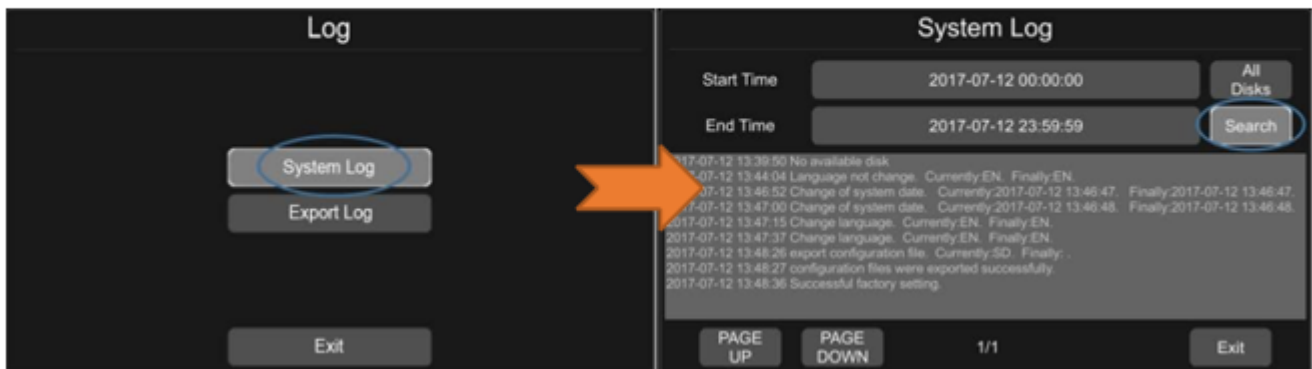

## DISPLAY MODE SWITCH



**Display Mode Button:** Click this button, or select it and press the SEL button to enter the display mode switching interface.



- ① Mode Selecting
- ② Press this button to set the currently selected mode to the default mode
- ③ Click to exit

## SYSTEM SETTING



**System Settings Button:** Click this button, or select it and press the SEL button to enter the settings menu. The prompt dialog box will display "Unable to record in set-up mode! Continue?". Press "OK" to enter.



## DISK MANAGEMENT



**Disk Management Button:** Click this button, or select it and press the SEL button to view the status of the storage device. If no storage device is inserted, a prompt of "No Disk Available" will appear.

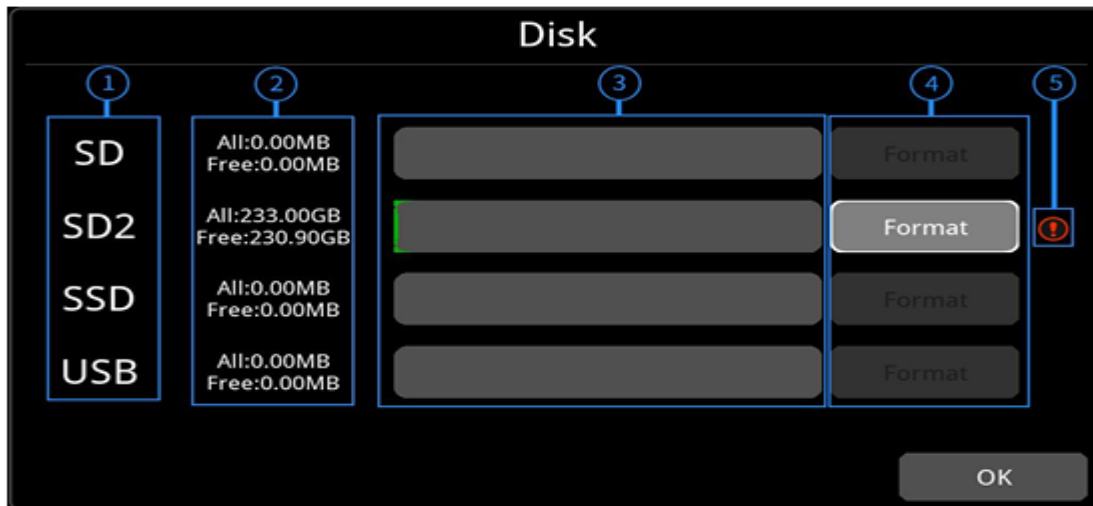

- ① Disk Type
- ② Disk Capacity
  - All: Total capacity of the storage device
  - Free: The rest available storage
  - If all displays 0.00MB, it means that the monitor cannot access such disks
- ③ Desk Capacity Bar
  - Green displays the size of all recording files in the "normal" list
  - Yellow displays the size of all other files except for the above ones
- ④ Press this button to format the SD card
  - The prompt dialog box will display "SD1 card data will be deleted! Continue?". Press "OK" to start formatting the disk
  - If the disk cannot be formatted, please check if it is damaged
- ⑤ This indicates that the disk need to be formatted before use
  - Normally, all new disks need to be formatted before use

## VOLUME



**Volume Adjustment:** On a scale of 0-10, default is 10

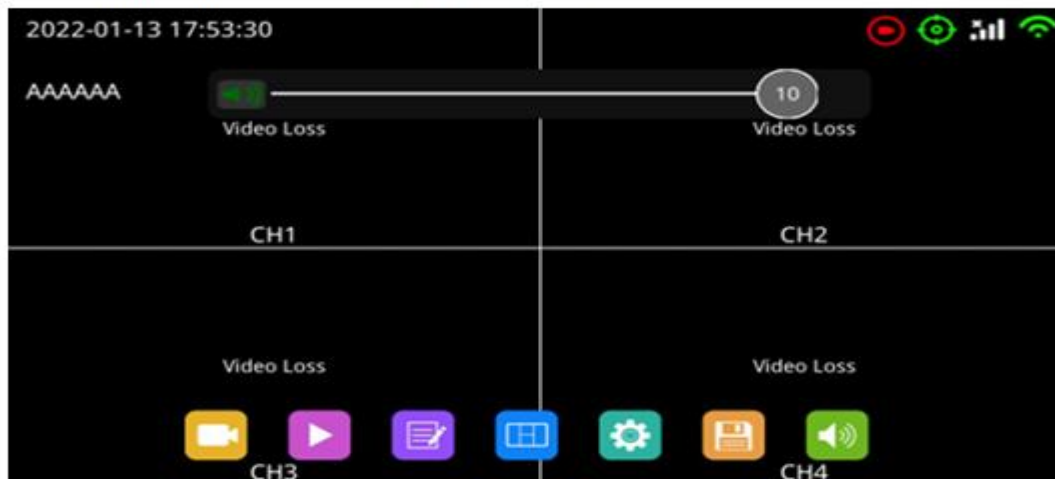

Function	Min.	Max	Default
Volume	0	10	10

## RECORD SETTING

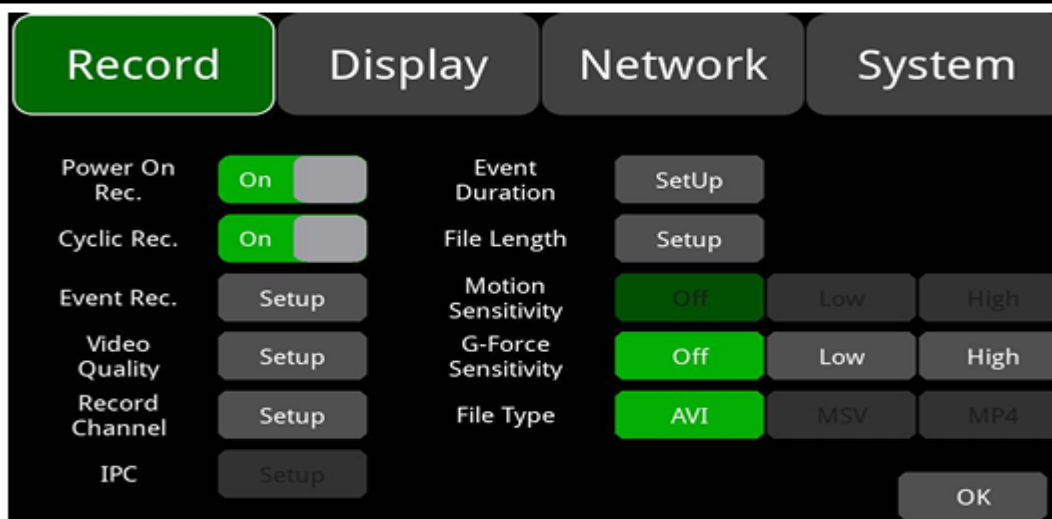

**Power-On Recording:** If this option is set on, the system will start recording after powering on, and this function is set on by default.



**Cyclic Recording:** If Cyclic Recording is set on, the new video file will overwrite the previous video files when the disk is full. Otherwise, recording will stop when the disk is full. This function is on by default and will soon overwrite recording files



**Event Recording:** Types of event recording include acceleration sensor triggered alarms and 1-5 triggered alarms. If event recording is on and the alarm parameters are set, the event recording will be triggered when the event occurs. If event recording is off, even if the event occurs, it will not trigger recording. The feature is set on by default.

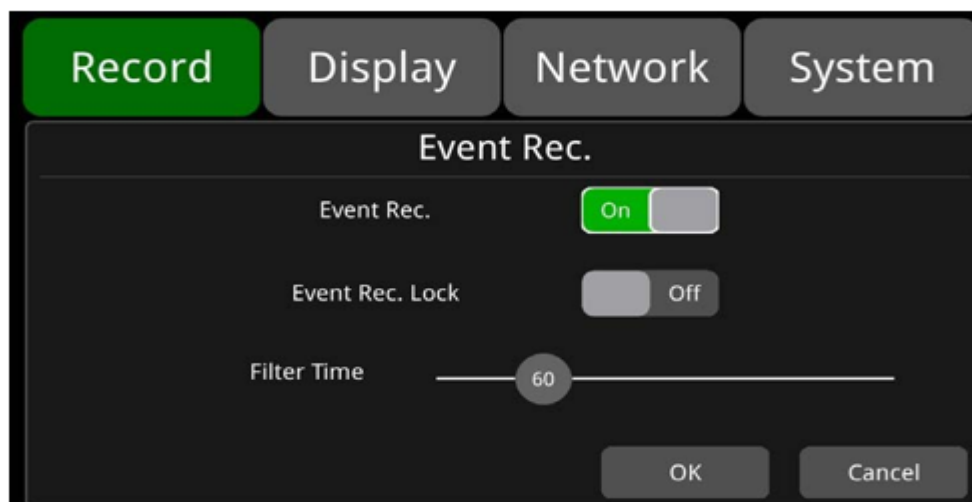

**Event Recording Lock:** When it is off, and when 20% of the disk storage is used by event recording, the new event recording will start overwriting the earliest recording file. When set on, recording overwrite will only cover normal recordings, not event recordings. Default setting is off.

**Filter Time:** Time Filtering, as shown in the figure above, if the same alarm is triggered continuously, an alarm message is generated every 60 seconds, and every 60 seconds there will be a detection to confirm whether a new alarm recording is generated. The minimum filtering time is 1sec, maximum 300secs. Default value is 60secs.

## VIDEO QUALITY

Video  
Quality

Setup

Record

Display

Network

System

### Video Quality

Main stream

Sub stream

JPG

Resolution

AUTO

Bitrate

AUTO

Framerate

20fps

Encrypt

Off

OK

Cancel

Main Stream is for video storage, while JPG is for WLAN streaming.

Default settings of Main Stream and JPG are as follows:

	Main Stream	Sub Stream	JPG
Resolution	AUTO	D1	NONE
Bitrate	AUTO	64Kbps	NONE
Framerate	20fps	25fps	LOW

① Five resolution options available for main stream: 1080P, 720P, D1(PAL), D1(NTSC), AUTO. The higher the resolution, the better video quality, and the larger the video file. All factors should be considered during configuration.

► In the "Resolution" option, "AUTO" is defined as follows:

	MAIN STREAM
AUTO	The monitor will indentify camera format and record videos of that format

② There are 8 levels of bitrate available in the mainstream menu: 4Mbps, 2Mbps, 1Mbps, 512Kbps, 256Kbps, 128Kbps, 64Kbps, **AUTO**. The higher the bitrate, the clearer the image, and the larger the recording files. All factors should be considered during configuration.

► In the "Bitrate" option, "AUTO" is defined as follows:

	MAIN STREAM
AUTO	If a 1080p camera is connected, the bitrate is 4Mbps. Likewise, 2Mbps for a 720p camera, 1Mbps for a D1 camera.

## VIDEO QUALITY CONTINUED...

③ There are 8 levels of framerate available in the mainstream menu: 30fps, 28fps, 25fps, 20fps, 15fps, 14fps, 10fps, 5fps. The higher the framerate, the smoother the image, and the larger the recording files. All factors should be considered during configuration

SD Capacity	Video Quality	File Length
2TB	4 x 1080P / 4Mbps	≈298h
	4 x 720P / 2Mbps	≈596h
	4 x D1 / 1Mbps	≈1193h
	1 x 1080P / 4Mbps	≈1200h
	1 x 720P / 2Mbps	≈2400h
	1 x D1 / 1Mbps	≈4772h
512GB	4 x 1080P / 4Mbps	≈75h
	4 x 720P / 2Mbps	≈149h
	4 x D1 / 1Mbps	≈298h
	1 x 1080P / 4Mbps	≈298h
	1 x 720P / 2Mbps	≈596h
	1 x D1 / 1Mbps	≈1193h

④ Four options for JPG framerate: Excellent, High, Mid, Low. Definitions are as follows:

Excellent	The speed at which images are uploaded to a webpage is unlimited (the fastest), thus rendering the smoothest image effect.
High	Upload Speed: 1sec for 1 image
Medium	Upload Speed: 3sec for 1 image
Low	Upload Speed: 5sec for 1 image

## VIDEO RECORDING / AUDIO CHANNEL

Record Channel

Setup

Video and audio channel selection. After selecting the corresponding channel, the video and audio will be recorded to this screen during normal recording.

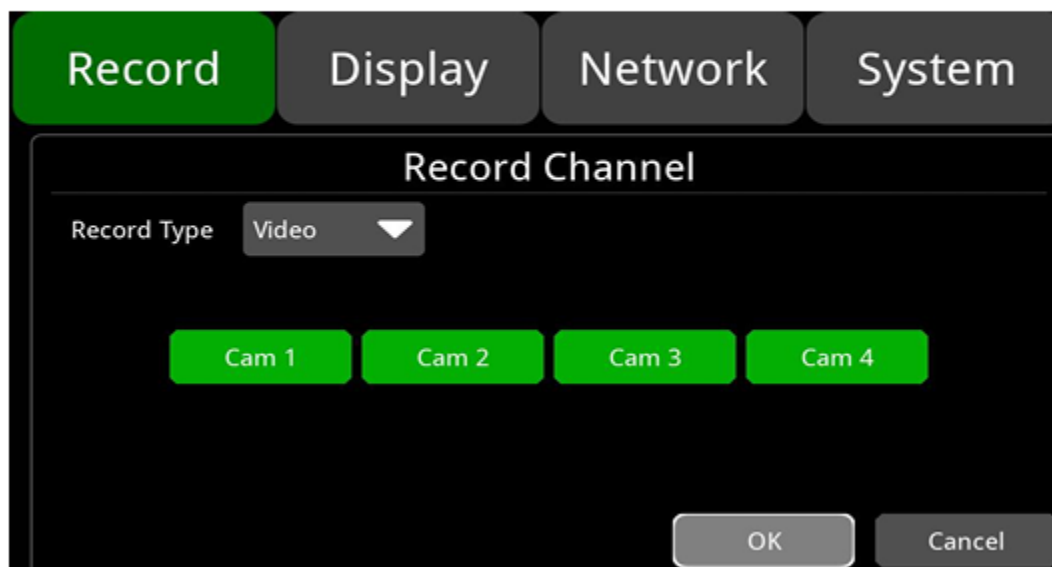

## EVENT DURATION

Event  
Duration

SetUp

When event recording is on, its file length can be set at 5sec-10sec

The screenshot shows a configuration window titled "Event Record Duration". At the top, there are four tabs: "Record" (highlighted in green), "Display", "Network", and "System". Below the tabs, the title "Event Record Duration" is centered. Underneath, there is a label "Alarm Rec Time(s)" followed by a text input field containing the value "10". At the bottom right, there are two buttons: "OK" and "Cancel".

## FILE LENGTH

File Length

Setup

The default recording file length for AVI format is 5 minutes. The length of AVI format video files can be set as 5min, 10min, and 15min.

The screenshot shows a configuration window titled "Record File Length". At the top, there are four tabs: "Record" (highlighted in green), "Display", "Network", and "System". Below the tabs, the title "Record File Length" is centered. Underneath, there is a label "File Length" followed by three buttons: "5min" (highlighted in green), "10min", and "15min". At the bottom right, there are two buttons: "OK" and "Cancel".

File Format	File Length
AVI	5 min, 10 min, 15 min

## G-FORCE SENSITIVITY



- G-Sensor recording and the setting of sensitivity level: When the acceleration or gyroscope of the G-Sensor reaches the preset sensitivity value, G-Sensor recording will be triggered. For this kind of event recording, the pre-record time will be set as 15s and the post-event time is configured by Event Duration above.
- Total video file length equals to the pre-recording file length (default time 15s) plus the file length, configured in Event Duration.
- If G-Sensor triggered recording is off, event recording will not be triggered. G-Sensor sensitivity can be set to two levels, low / high. G-Sensor triggered recording is on when low / high is selected. G-Sensor triggered recording is off when OFF is selected.

## DISPLAY



## CAMERA NAME SETTING



Camera Names are displayed at the bottom of each channel. Touch the “Display → Camera Name → Cam” on the menu, a keyboard will pop up to input a new camera name. Maximum 8 characters can be entered and the camera name must NOT be blank. The default configuration is shown below.

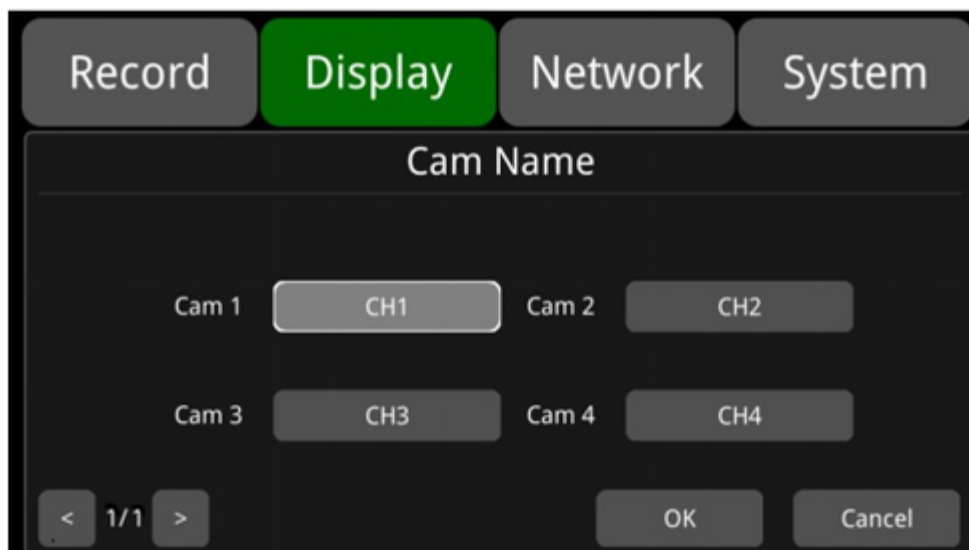

## CAMERA DISPLAY SETTING



Camera parameter setting for each corresponding channel includes brightness, contrast, saturation and hue. The default values of brightness, contrast, saturation and hue of all channels are shown in the figure below. To change the value, drag the bar to left or right to decrease or increase.

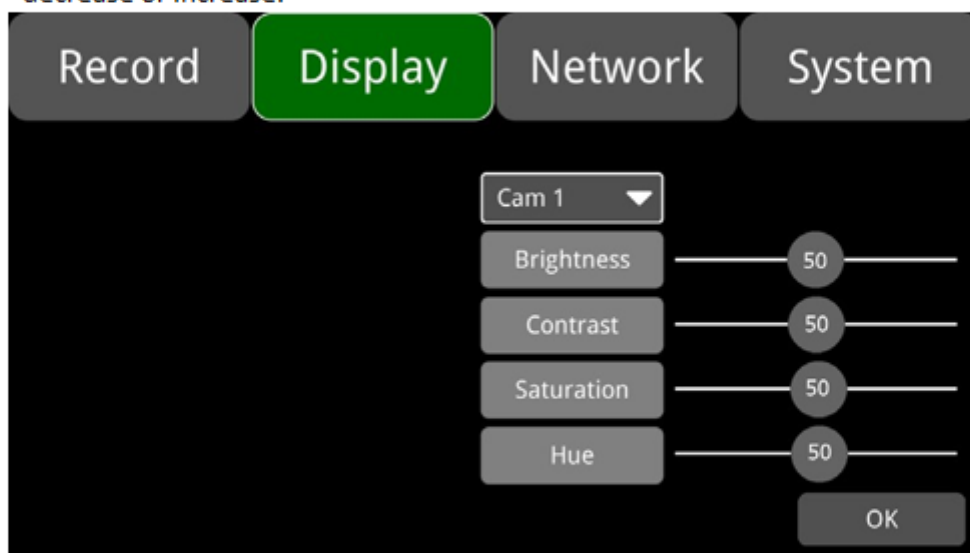

Camera Display	Min.	Max.	Default
Brightness	0	99	50
Contrast	0	99	50
Saturation	0	99	50
Hue	0	99	50

## SYSTEM LANGUAGE SETTING



**Menu Languages:** Currently only English, Russian, and Chinese are available. The default language is English.



## AUDIO OUT



**Audio Out:** Select the audio output channel in multi-display mode. The default configuration is shown below.



## OSD DISPLAY



Time, Camera name, License number and Speed can be selected whether or not to be displayed. If selecting on, the information will be shown in the live and the playback video. The default configuration is shown below.

Record	Display	Network	System
OSD			
Time	<input checked="" type="checkbox"/>	ADAS	<input checked="" type="checkbox"/>
Camera Name	<input checked="" type="checkbox"/>	DMS	<input checked="" type="checkbox"/>
License No.	<input checked="" type="checkbox"/>	BSD	<input checked="" type="checkbox"/>
Speed	<input type="checkbox"/> Off	APC	<input checked="" type="checkbox"/>
		OK	Cancel

## MENU ON



Set the menu display duration. The default configuration is shown below.

Record	Display	Network	System
Menu On			
30s 60s 120s Always			
Menu Lock	<input checked="" type="checkbox"/>	OK	Cancel

**Menu lock:** Menu on duration can be set to 30sec, 60sec, 120sec, and Always. When set to 30sec, 60sec, or 120sec, that is, after opening the menu, if there is no operation in 30sec, 60sec, or 120sec, the menu will be hidden. When it is set to always, the menu will always be open. Please be note that the recording will stop when menu is on. It is not suggested to set the duration to Always in order not to affect the recording.

**On:** When it is On, permission is required to enter the menu

**Off:** When it is Off, no permission is required to enter the menu

► Username "admin" and corresponding password are required to change the status of the menu lock

## SPEED



**Speed Setting:** The overspeed info comes from GPS (Source). Speed unit is optional: Km/h or Mile/h; Overspeed threshold can be set by user. Duration is the overspeed alarm time. Speed means the current vehicle speed. If the Speed continues to exceed the Overspeed value for a time longer than Duration, the monitor will trigger an overspeed alarm recording.

- ▶ The alarm switch is to set the over-speed alarm recording status. If it is ON, the overspeed alarm recording will be triggered when there is an overspeed event. If it is OFF, the overspeed alarm recording will not be triggered.

Overspeed	Min.	Max.	Default
Km/h	0	200	120
Mile/h	0	125	75

## GPS



**GPS:** When the GPS antenna is properly installed, the speed info will be recorded to the files. The menu provides GPS information including latitude, longitude, detectable satellites, and accessible satellites etc.

**Mode:** GPS connection status

**Used:** The number of available satellites

**Visible:** The number of searchable satellites

# MIRROR



Horizontal and vertical flips of all channels are turned off by default.

**Horizontal:** when it is set to ON, the corresponding recording channel will flip horizontally; when it is set to OFF, there will be no flip. Below are setting steps



**Vertical:** When it is set to ON, the corresponding recording channel will flip vertically; when it is set to OFF, there will be no flip. Below are setting steps.



## BACKLIGHT



**Backlight Adjustment:** Adjust monitor backlight brightness

- ▶ When AUTO is set to OFF, only DAY backlight can be adjusted.

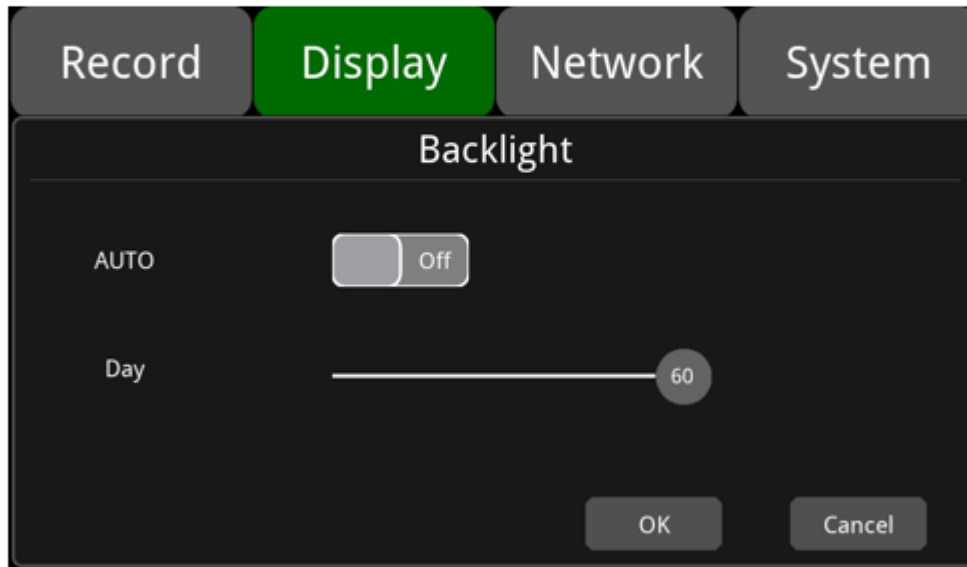

- ▶ When AUTO is set ON, both DAY and NIGHT backlight can be adjusted. The monitor will automatically adjust the backlight brightness based on the ambient light. When the environment is bright, the backlight of the monitor is set to DAY, and when it is dark, the backlight will be set to NIGHT.

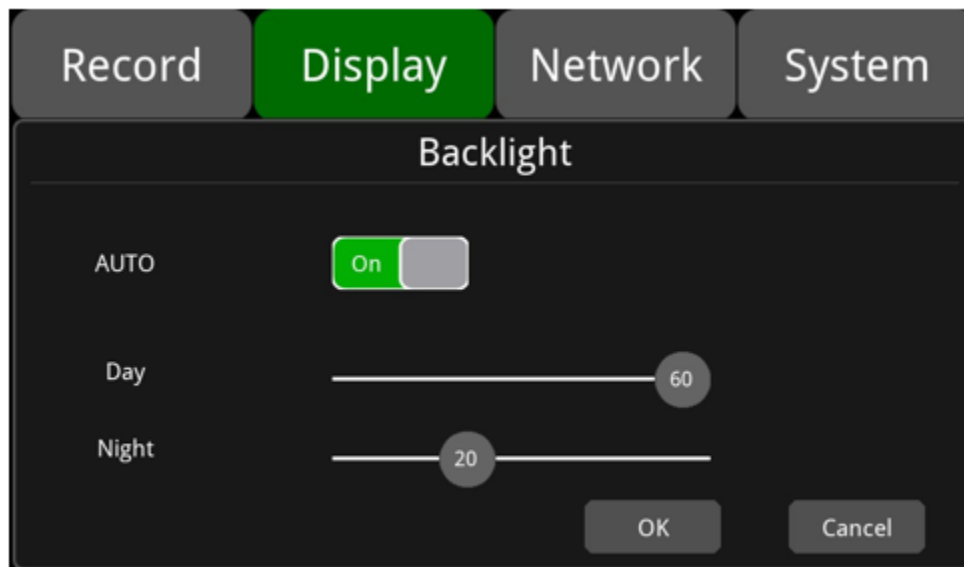

## LAN & SERVER SETTING

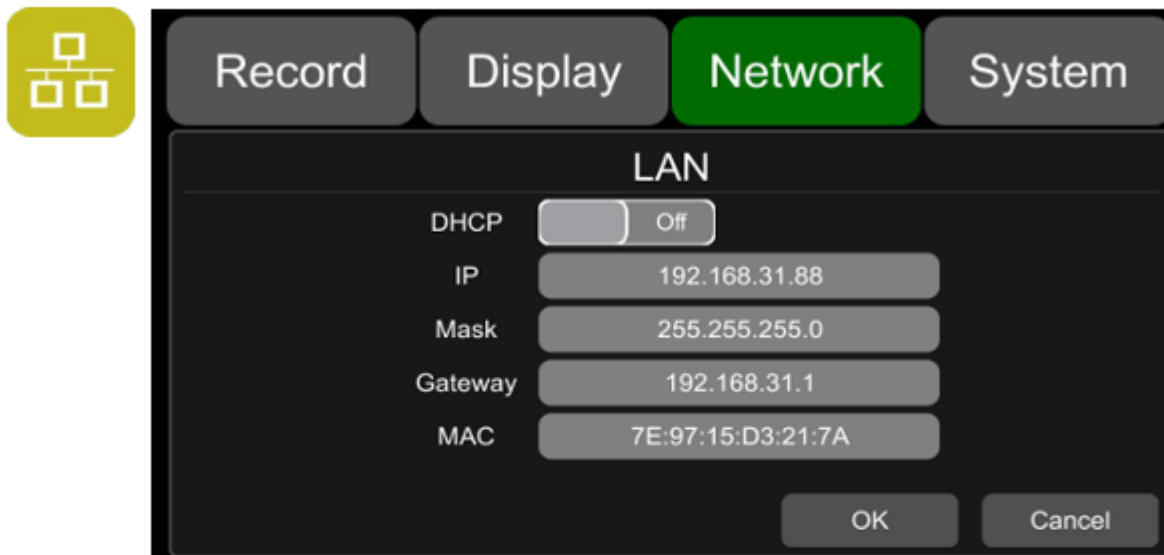

**DHCP:** Dynamic Host Configuration Protocol. Set On for dynamic IP and Off for static IP. Static IP requires input with IP address, mask and gateway

### LAN Connection:

- ▶ Step 1: Connect the LAN cable to the DVR
- ▶ Step 2: Go to "Network → LAN" Page
- ▶ Step 3: If DHCP is set to ON, a dynamic IP will be automatically matched. If DHCP is set to Off, input the IP, mask, gateway and MAC manually
- ▶ Step 4: Touch OK to exit
- ▶ Step 5: Go to "Network - Server" page and touch the LAN icon
- ▶ Step 6: Input LAN Server IP and Port. Touch OK to save the settings



## WI-FI NETWORK SETUP & SERVER SETUP

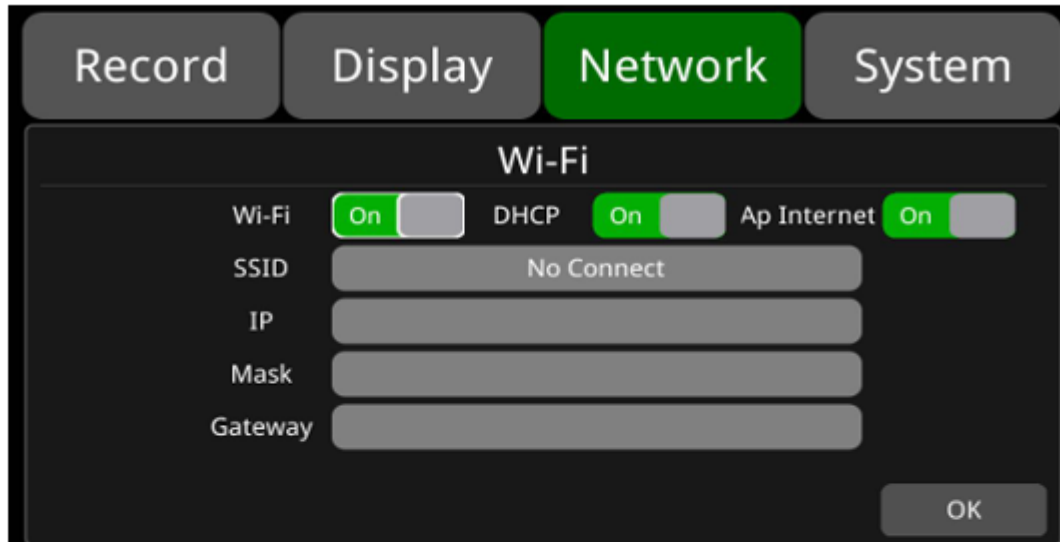

### WIFI: ON/OFF

**DHCP:** Dynamic Host Configuration Protocol. Set On for dynamic IP and Off for static IP. Static IP requires input with IP address, mask and gateway

**SSID:** Wi-Fi Connection

**AP Internet:** The hotspot of the device can be found on mobile phones when it is ON.

### WIFI Connection:

- ▶ Step 1: Make sure Wi-Fi hotspot is available
- ▶ Step 2: Connect the Wi-Fi antenna to the rear panel of the device.
- ▶ Step 3: Go to Wi-Fi setup interface, set Wi-Fi to ON and DHCP to ON.
- ▶ Step 4: Touch SSID sub-menu to select the hotspot and input the password
- ▶ Step 5: Touch OK to exit.
- ▶ Step 6: Go to "Network → Server" page to input Wi-Fi Server IP and Port. Touch OK to save the settings.
- ▶ Step 7: Wi-Fi network status and server status can be checked on "Network → Status". Wi-Fi Status shows "CONNECT SUCCESS" and the Server Status shows "Online".



## WI-FI NETWORK SETUP & SERVER SETUP CONTINUED...

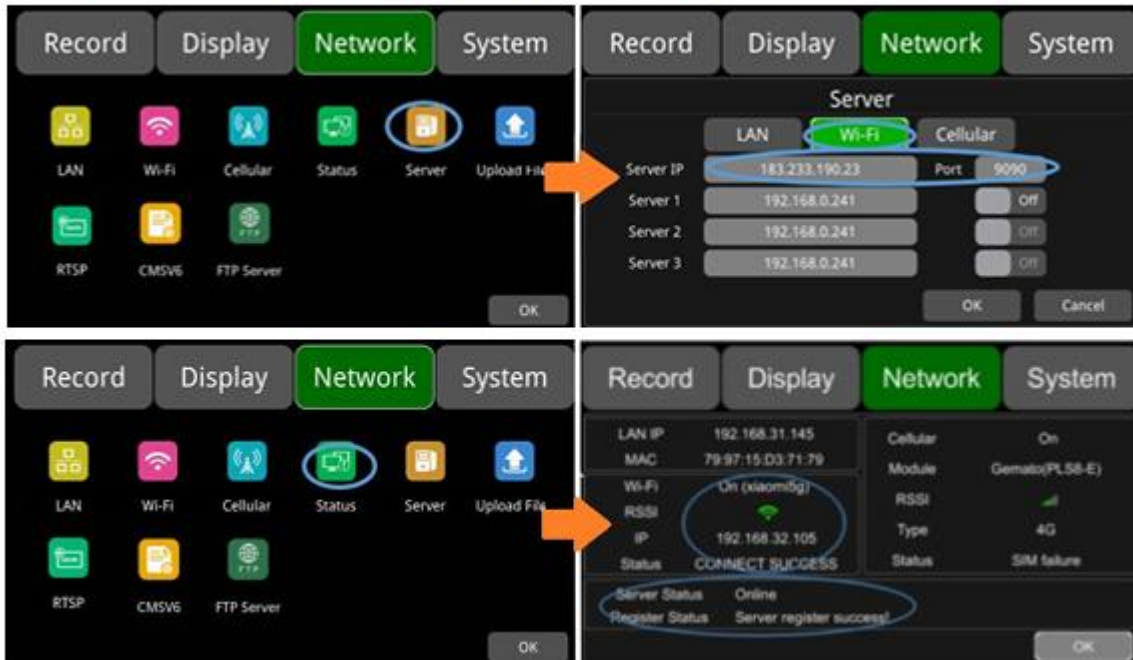

## 2G / 3G / 4G CONTROL AND SETUP

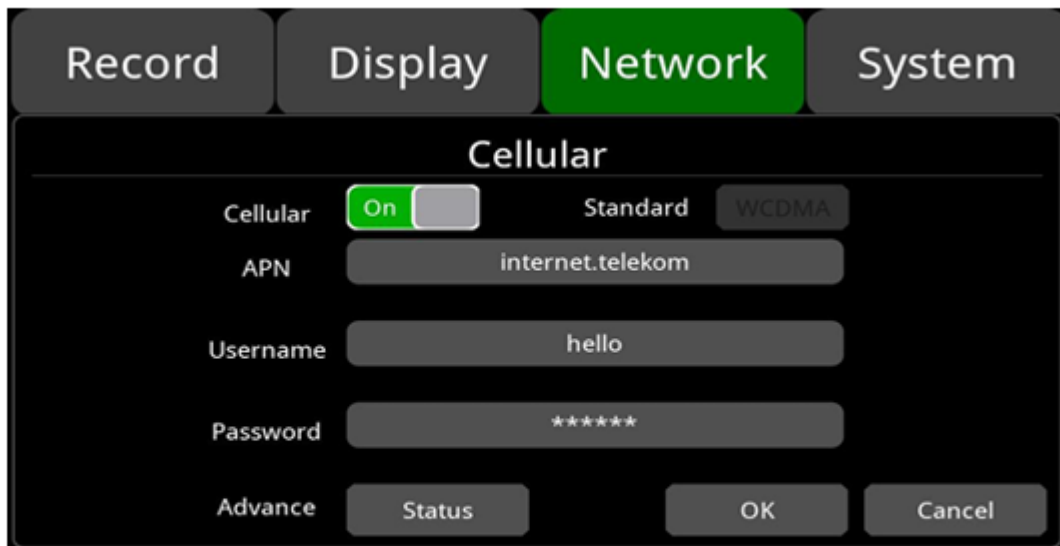

**Cellular:** If Cellular is on, it means that 2G/3G/4G is on

**APN.:** Normally, the default values for APN,, and the user name and password are not necessary. If the connection is not successful under the default settings, please consult your local network carrier.

**Network Standard:** The default is WCDMA.

**Username & Password:** Provided by and to consult the local network carrier.

## 2G / 3G / 4G CONTROL AND SETUP CONTINUED...

### 2G/3G/4G Connection

- ▶ Step 1: Search 2G/3G/4G signals locally.
- ▶ Step 2: Connect the 2G/3G/4G antenna to the rear panel of the device.
- ▶ Step 3: Open the front panel of the device and insert the SIM card.
- ▶ Step 4: Go to Cellular setup interface and set Cellular to ON.
- ▶ Step 5: Enter the correct APN and Access number. The latter is optional.
- ▶ Step 6: Touch OK to save the settings and exit.
- ▶ Step 7: Input the 2G/3G/4G Server IP and Port on "Network → Server"
- ▶ Step 8: Cellular network status and server status can be checked on "Network → Status". Wi-Fi Status shows "CONNECT SUCCESS" and the Server Status shows "Online".



## AP INTERNET SETUP



### Steps to connect AP Internet

- ▶ Step 1: Connect the DVR to the internet through Wi-Fi or 2G/3G/4G. Please refer to Chapter 10.2 and 10.3 for connection.
- ▶ Step 2: Set the "AP Internet" to ON.
- ▶ Step 3: Search and connect to the Wi-Fi hotspot of the DVR with other mobile devices. The SSID name of the hotspot is prefixed with "WFD-" and followed by the serial number of the device. The default password of the hotspot is ap12345678.

## SERVER



The function of the server setting is mentioned in Chapters 10.1 and 10.2. The default server IP of Wi-Fi and Cellular are "183.233.190.23", and the default port number is "9090".

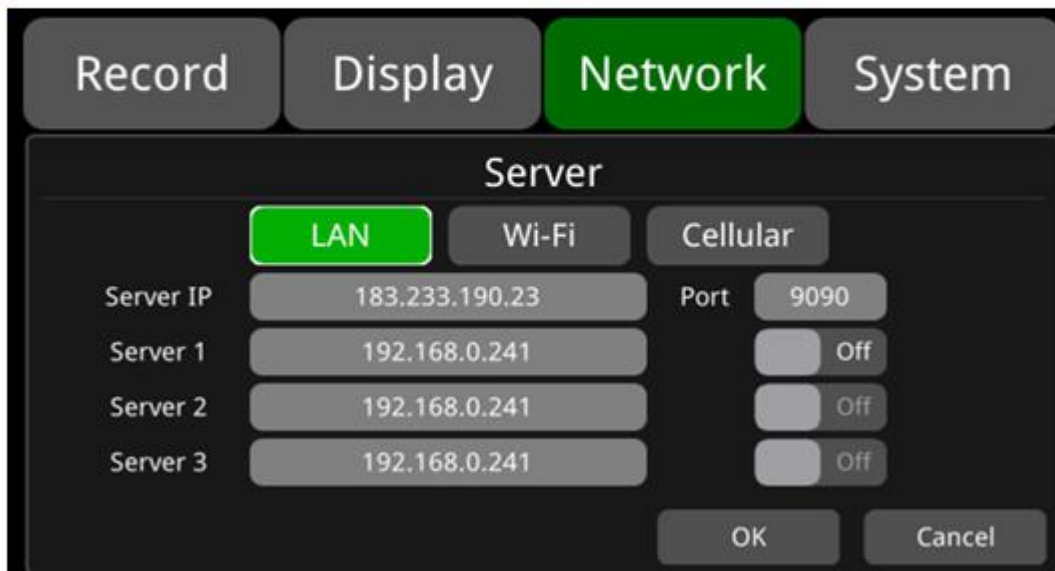

## NETWORK STATUS



**Network Status:** LAN IP address, MAC address, Wi-Fi network status, Wi-Fi IP address, Wi-Fi signal strength, cellular network status, cellular signal strength and server status, etc. can be checked. In addition, the user can verify that the network connection is successful.

Record	Display	Network	System
LAN IP	192.168.31.111	Cellular	On
MAC	7e:97:15:d3:d3:1d	Module	Serrria
Wi-Fi	On	RSSI	
RSSI		Type	2G
IP	192.168.32.215	Status	SUCCESS
Status	CONNECT SUCCESS		
Server Status	Online		
Register Status	Server register success!		

OK

Description	Indication
Module Initialization	The cellular module is initializing
Module Exception	The cellular module is in exception
No SIM Card	No SIM card is found in the DVR
C-Pin Locked	C-Pin is locked
Signal Abnormal	The signal is abnormal
Networking Failure	The network connection failed
Success	The network connection is successful

- **LAN IP:** The static IP set on Network → LAN page or the dynamic IP obtained automatically
- **MAC:** The static physical address set on “Network-LAN” page or the dynamic physical address obtained automatically.
- **Wi-Fi IP:** Static IP obtained from “Network-Wi-Fi” page or dynamic IP address obtained automatically.
- **Cellular RSSI:** 2G/3G/4G signal strength indication.
- **Cellular Type:** 2G, 3G or 4G, indicating the actual signal received.
- **Cellular Status:** Please refer to the descriptions and indications above.
- **Wi-Fi:** Status indication.
- **Wi-Fi RSSI:** Wi-Fi signal strength indication.
- **Wi-Fi status:** Connect Success or Get IP Error.
- **Cellular:** Status indication.
- **Module:** The Cellular module brand.
- **2G:** Receive 2G signals.
- **3G:** Receive 3G signals.
- **4G:** Receive 4G signals.
- **Server Status:** Online / Offline.
- **Register status:** Reasons for failed server connection.

## FILE UPLOAD



The default configuration of "Upload Files" is shown below

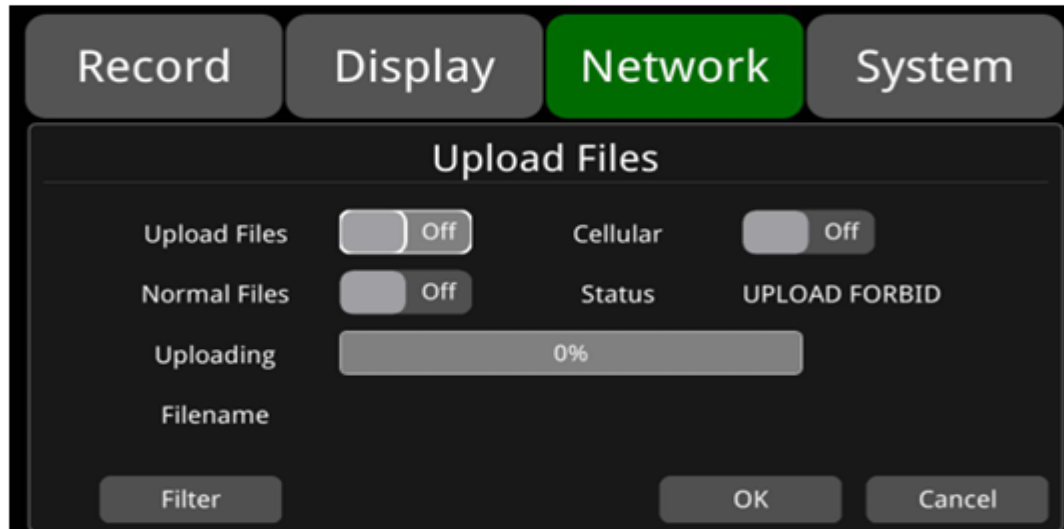

**Upload Files:** ON/OFF. When set to ON, the alarm video file will be uploaded to the server as long as the alarm video recording is triggered. When set to OFF, the alarm video file will not be uploaded to the server, though the recording can still be activated

**Normal File:** Two States, "OFF / "ON"

- Off: Cannot upload normal video files
- On: Upload normal video files

**Cellular:** Two States, "OFF / "ON"

- Off: Normal video files are not allowed to be uploaded when connecting to the server with Cellular. For example, the setting in the figure below means that normal video files will only be uploaded when connecting to the server with LAN or Wi-Fi instead of Cellular.



- On: File uploads are allowed when connecting to the server with Cellular. When the switch is turned on, a pop-up box will prompt "Network flow consuming, continue?" Click "OK" to confirm the opening. However, after this feature is turned on, once the server is connected with Cellular, video files will be uploaded, causing a lot of cellular flow consuming. So in order to save cellular flow, please set to "OFF".





## MINISTRY STANDARD



The default configuration is shown below

Record Display **Network** System

Bu Biao

Ministry Standard **Setup**

OK Cancel

Ministry Standard

Net Model **IP** Domain 0.0.0.0

Proto **TCP** UDP 8888

Phone

License plate

OK Cancel

**Net Model:** IP or Domain are available. Fill in the IP of the ministry standard platform if IP is chosen; and the Domain if Domain is chosen.

**Proto:** TCP or UDP are available. Fill in the port of the corresponding ministry standard platform.

**Phone:** Configure the corresponding phone number. Able to check the status of the device by choosing the corresponding phone number in the ministry standard platform.

## FTP SERVER SETTING



The default configuration is shown below

Record Display **Network** System

FTP Server

FTP  Off

Username

Password

OK Cancel

**FTP:** If it is set to Off, it means the FTP server is not turned on. Set it to On, then the FTP server is turned on.

**Username:** The user name to log in to the FTP server.

**Password:** The password to log in to the FTP server.

## SYSTEM



## SYSTEM - LOG IN SETTING



**Log In Setting:** Set user name and password for entering the menu. The initial password is 123

Record Display Network System

User

Username

Password

New Password

Confirm Password

OK Cancel

## SYSTEM - LICENSE PLATE NUMBER



**License Plate Number:** Input license plate number. Default setting is as below:

Record Display Network System

Device

License No.

Device ID

OK Cancel

## SYSTEM TIME



Format Setup: system time format setup

Format default configuration is shown above

Go to System → Date & Time → Format → Setup page

- ① **Time Zone:** Time zone setting
- ② **Date Format:** Date format setting
- ③ **24 Hour:** If it is ON, time will be displayed in 24-hour format. If OFF, 12-hour format
- ④ & ⑤ **Hour & Minute:** Time zone setting is accurate to minute

Hour & Minute	Min.	Max.	Default
Hour	-12	14	8
Minute	0	59	0

Time Sync default configuration is shown above

Go to System → Date & Time → Time Sync → Setup page

- ① **GPS:** Set GPS to ON/OFF
- ② **NTP:** Set NTP to ON/OFF
- ③ **NTP Server:** Show the URL of the NTP Server

## SYSTEM TIME CONTINUED...

Application Scene	Usage
GPS: OFF & NTP: OFF	Set the time zone and daylight saving time (DST) first, then set the date and time
GPS: ON or NTP: ON	Time zone and daylight saving time (DST) must be set, no need to set date and time

► **Note:** When Time Sync → GPS or Time Sync → NTP is ON, the time zone and daylight saving time must be set; if the time zone is not set, GPS and NTP will change the system time to the default East 8 zone time, which might cause incorrect device time.



DST default configuration is shown above

Go to System → Date & Time → DST → Setup page

- ① **Enable:** Set DST setting to ON/OFF
- ② **Offset:** Adjust the offset after enabling DST
- ③ **Mode:** Select the mode of DST (setup DST according to the week or date)
- ④ **Start Time:** Set start time of DST
- ⑤ **End Time:** Set end time of DST

## SYSTEM - SCHEDULED RECORDING



	Enable	Start	End	Weekday
Schedule 1	<input type="checkbox"/> Off	00:00	01:40	Setup
Schedule 2	<input type="checkbox"/> Off	00:00	01:40	Setup
Schedule 3	<input type="checkbox"/> Off	00:00	01:40	Setup
Schedule 4	<input type="checkbox"/> Off	00:00	01:40	Setup

The default configuration is shown above

**Enable:** Set scheduled recording ON/OFF

**Start:** Set start time of scheduled recording

**End:** Set end time of scheduled recording

**Weekday:** Set scheduled recording by weekdays. Select the weekdays to schedule recording

### Scheduled Recording:

- ▶ Support up to four appointed tasks. The recording duration is counted in minutes
- ▶ Recording time can overlap
- ▶ The start time of scheduled recording must be set ahead of the end time

## SYSTEM - ACC



The default configuration of "Shutdown Voltage" and "ACC Duration" is shown above

**Current voltage:** Working voltage of the monitor

**Shutdown voltage:** When the current or voltage is lower than the shutdown voltage, the device will shut down automatically

**ACC Duration:** The device will continue recording for some time after ACC is disconnected. ACC duration can be set to 5sec to 60 min

ACC	Min.	Max.	Default
Shutdown Voltage (V)	9	24	10
ACC Duration (s)	5	3600	5

## SYSTEM - EXCEPTION



It can be set to examine the recording status of the monitor.

If the monitor does not generate normal recording videos, the buzzer will issue an alarm.

For stopping the alarm, please check whether the monitor is recording

Buzzer Alarm function works as below:

- ▶ The buzzer will beep long, for all types of recordings except for the trigger ones
- ▶ If the buzzer alarm is not required, users can enter the "System"-> "Exception" page and set the buzzer from "ON" to "OFF". Please note that if the buzzer is set to OFF, it will not sound if there is no normal recording. But this function does not affect triggered event recording.



Different beep modes represent different working states, as shown below:

If the buzzer beeps intermittently, it indicates that the monitor is not recording.

- ▶ Without SD card: one long beep + two short beeps
- ▶ SD card file system bug: one long beep + three short beeps
- ▶ When the SD card is normal, the recording file is full, and the recording overlay is not opened: two short beeps+ one short beep
- ▶ No camera input: two short beeps + two short beeps
- ▶ When the SD card is normal but the monitor is not recording: two short beeps + three short beeps

## SYSTEM - ALARM



**Alarm 1~Alarm 5:** Customized alarm recording

**Priority:** Set priorities for Alarm 1 to Alarm 5

- ▶ When different types of alarm are triggered at the same time, alarms with the highest priority will work first

## SYSTEM - ALARM CONTINUED...



"Alarm 1-4" default configuration is shown above

- ▶ **Trigger Level:** There are 3 options of Trigger Level. The options "Low" and "High" are for turning on alarm function. "Low" is generally used for debugging while "High" is set to enable alarm function for on-road use. "Off" is to disable trigger alarm function
- ▶ **Output Duration:** "Display" "Cursor" "Alarm Out" effect duration. Output Duration time is optional: 0s, 5s, 10s, 30s, 60s, 5min, 10min, 30min, 60min, Always
- ▶ **Alarm Out-Buzzer:** Switch ON or OFF of the Alarm Out-Buzzer. Alarm time is 5 seconds by default
- ▶ **Alarm Out-Output1:** When it is set ON, Alarm 5 (Out) will output alerts from Output 1
- ▶ **Alarm 1 Rec.:** Alarm 1 event recording switch, the recording duration is set in [System] → [Record] → [Event Duration].
- ▶ **Display:** When the alarm is triggered, the selected split mode will be displayed; the available split modes are shown in the figure below

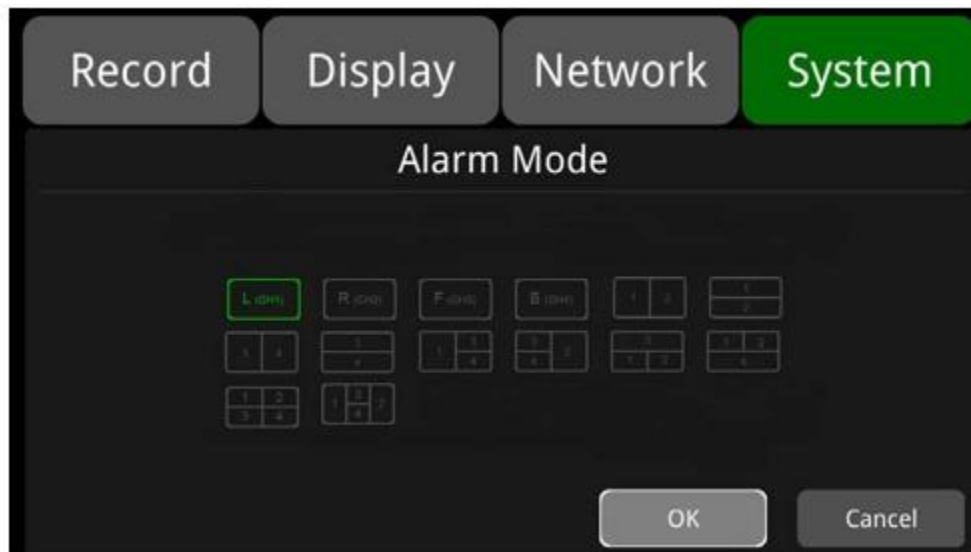

## SYSTEM - ALARM CONTINUED...

► **Cursor:** It is "OFF" by default. The picture below shows the "ON" state

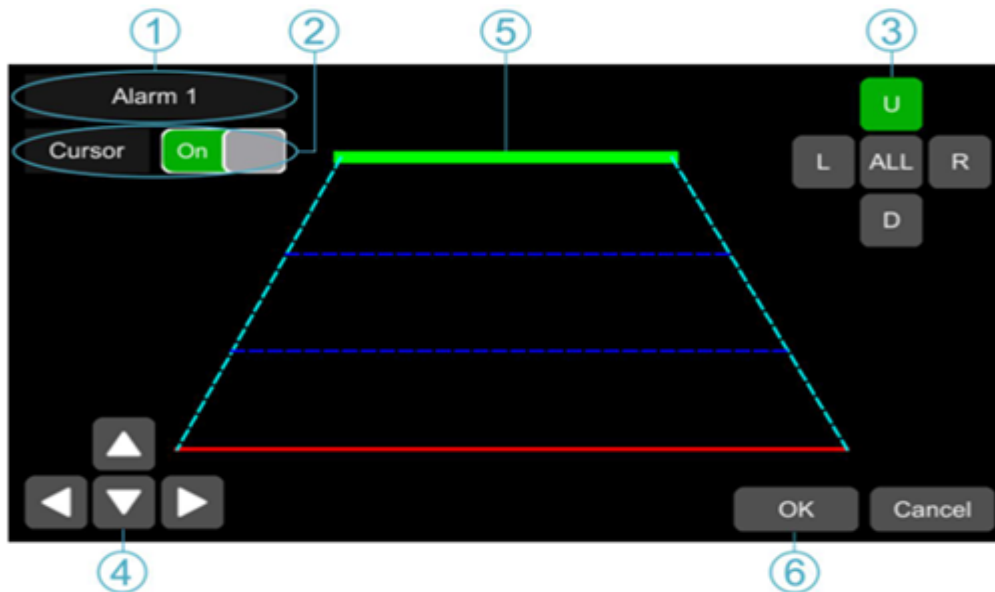

- ① Alarm type
- ② Touch to turn on/off the cursor
- ③ Line selecting: Line U (up), Line D (down), Line L (left), Line R (right) and ALL. Green means being selected. Remote control operation is available
- ④ Click the 4 directions (Up, Down, Left and Right) to adjust the shape of the cursor. The movements only affect the selected lines
- ⑤ Lines of cursor: The selected line will thicken for threefold. The two lines in the middle will not
- ⑥ Touch "OK" to save the settings and exit. Cancel to exit without saving any settings.

► **Priority:** The default configuration is shown below

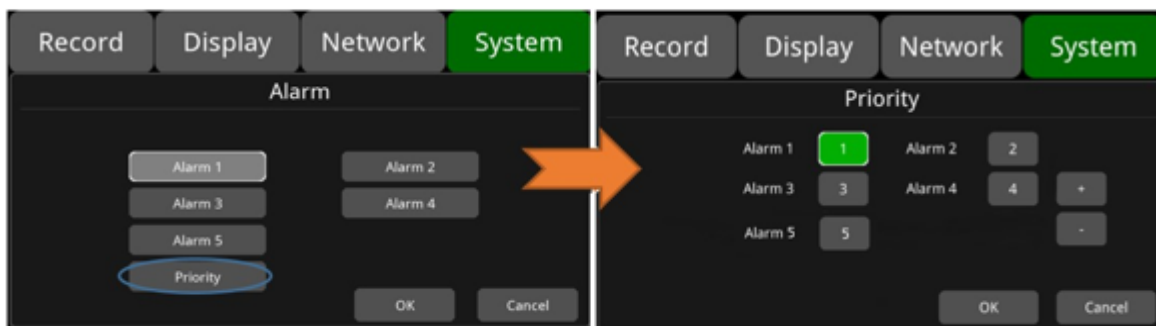

Touch to decrease trigger priority. The bigger the value, the lower the priority



Touch to increase trigger priority. The smaller the value, the higher the priority

- Alarms with higher priority will be triggered first
- 1 stands for the highest priority, and 5 the lowest
- If two alarms A and B are triggered at the same time, and A's priority is higher than B's, then A will be recorded first. After A finishes the recording, if B is still being triggered, B will be recorded then. If B is no longer being triggered, it will not be recorded
- If alarm B is triggered and recorded, and then alarm A, whose priority is higher than B is triggered, alarm B recording will not stop

## SYSTEM - UPDATE



► For single device

**Step 1:** Copy the files to the SD card/upgrade/package/local directory, insert the SD card into the monitor

**Step 2:** Go to Menu → System → Update → Software, touch “OK” to confirm the update.

**Step 3:** When “Update success!” is shown on the display, the device will reboot automatically

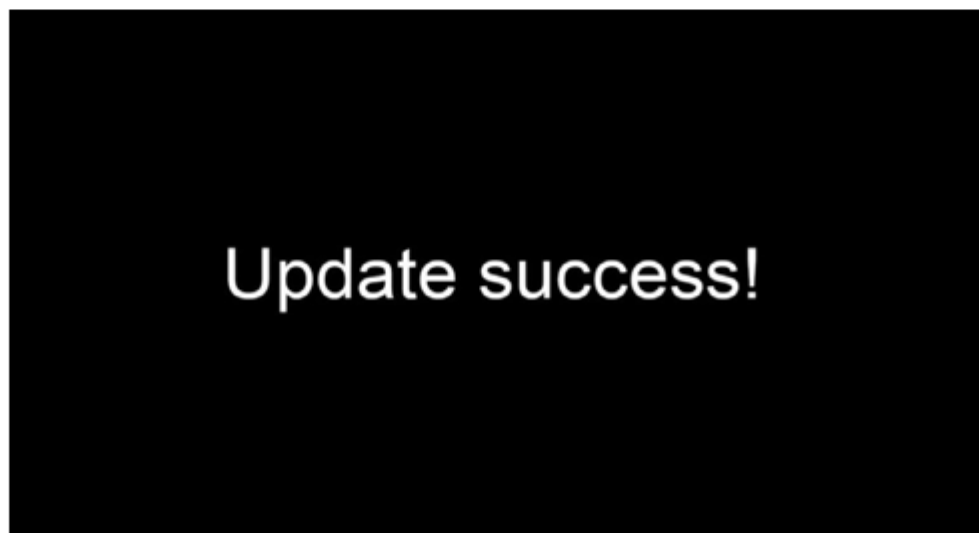

**Step 4:** After rebooting, please check if the version is the same as the one you copy into “upgrade” folder.

Instruction: Menu → System → Info

**Note:** After the upgrade is completed, the upgrade package in the SD card/upgrade/package/local directory will be renamed as “old\_update\_packet”.

## SYSTEM - CONFIGURATION



**Configuration Import:** Import the configuration information from the flash memory device and place the configuration file in the "sd/export\_file/config" directory.



► **Configuration export:** Export configuration information to a flash device



► **Buzzer Enable:** When turn On, buzzer will alarm when there is touch screen operation and the device is responding the remote control demand



► **Factory Default:** Press "Reset" to restore factory settings

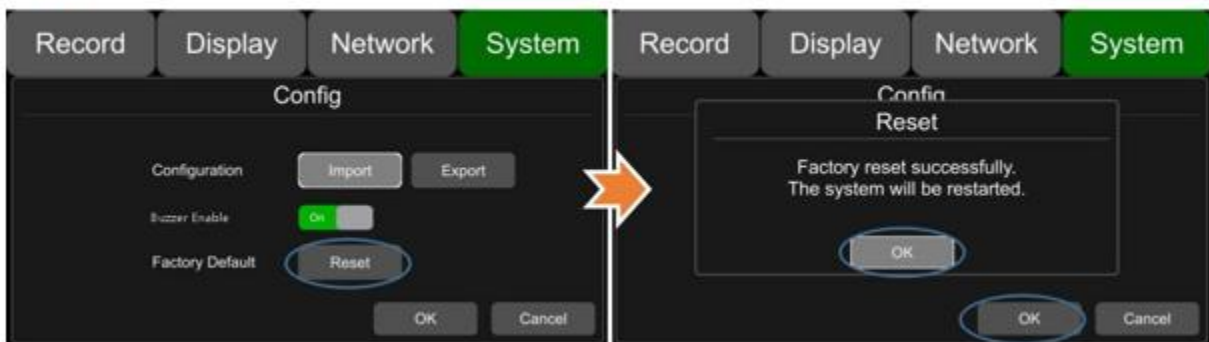

## AI CONFIGURATION



AI: Algorithm function is composed of ADAS, DMS, BSD and APC. After selecting the function, the device will automatically restart, and the corresponding functions can be configured then.



## ADAS

ADAS Algorithm: Provide FCW (Front Collision Warning), LDW (Lane Departure Warning), PDW (Pedestrian Detection Warning), HMW (Headway Monitoring Warning), Front Vehicle Start Reminder, SSR (Speed Limit Sign Recognition) and Overspeed Warning. Improve driving safety by helping drivers get aware of potential risks and avoid collisions. The following pictures show the default configuration interface:

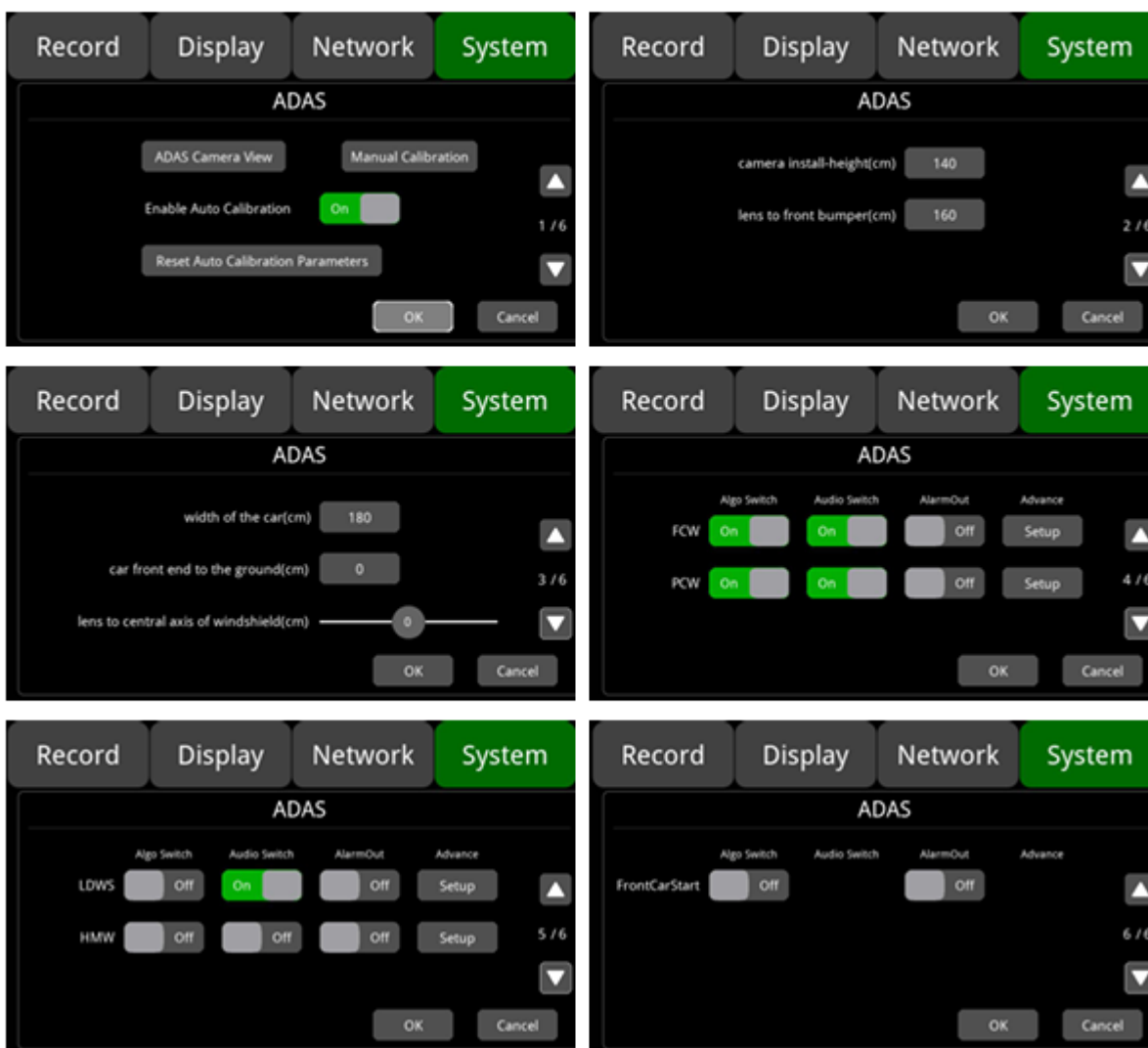

## ADAS CONTINUED...

**ADAS Camera View:** Click ADAS camera channel to check the current camera footage, to confirm the pitch angle and assist the installation of ADAS camera. As shown in the picture below:

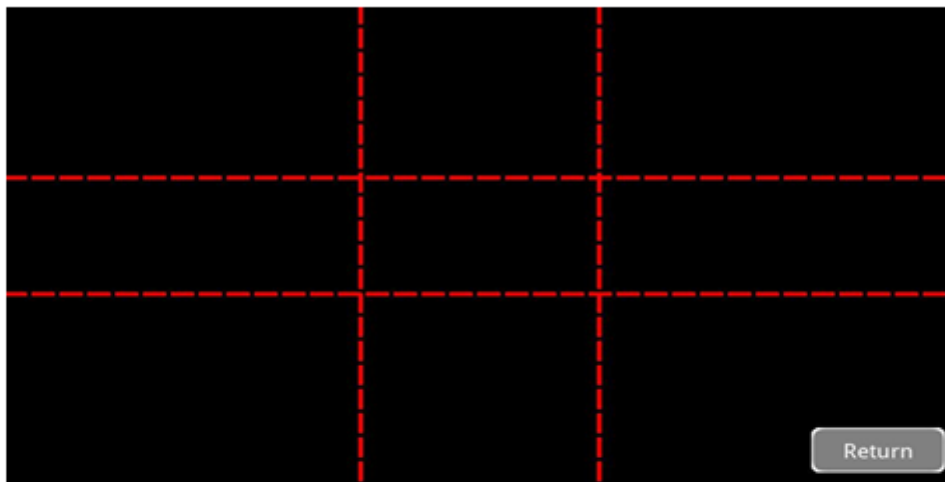

**Manual Calibration:** Parameter manual calibration. Click to enter the following prompt window:



Click OK will reset the automatic calibration parameters, and enter the manual calibration interface, as shown below:

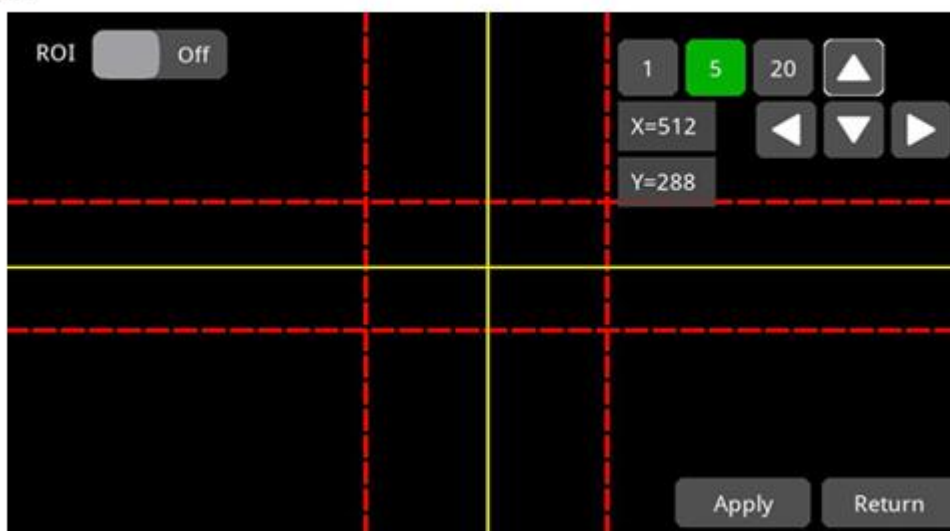

## ADAS CONTINUED...

Adjust the camera position when install it on the vehicle. Take the contour mark line as an example, the interface is as shown below. The contour mark can be changed to road vanishing line as the reference object if needed. 1, 5, and 20 are moving unit scales; click the up and down icons to adjust "Y" value, click the left and right icons to adjust "X" value.

**ROI:** Visualization of the detection area. When set On, you can see detection area scope in the calibration interface, as shown in the picture below:

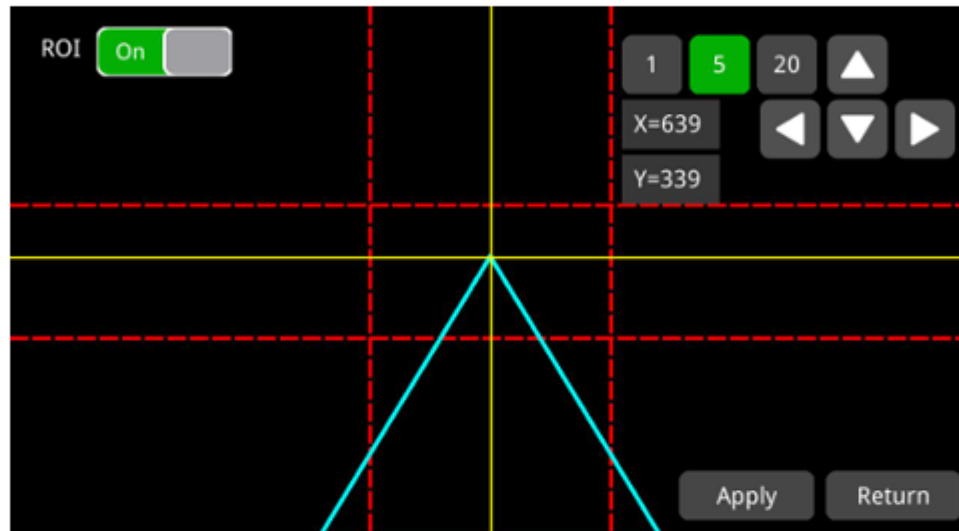

**Enable Auto Calibration:** Automatic calibration switch. When set to On, automatic calibration starts when the lane detection works fine and the speed reaches 40km/h/.On by Default

**Reset Auto Calibration Parameters:** Re-calibrate automatically. When set to On, the previous calibration result is reset until the automatic calibration succeed.

**Camera install-height(cm):** Front view camera installation height is set to 150 cm by default, ranging from 140-250.

**Lens to front bumper(cm):** Distance from lens to front bumper is set to 160 by default, ranging from 0-600.

**Width of the car(cm):** Vehicle width is set to 180 by default, ranging from 150-300

**Car front end to the ground(cm):** Distance from vehicle front end to the ground is set to 0 by default, ranging from 0-250.

**Lens to central axis of windshield(cm):** Distance from lens to front windshield axis is set to 0 by default, ranging from -5-+5.

**Algo Switch:** When set to On, if the estimated TTC Thresold(s) is less than the configured time, an alarm will be triggered. When set to Off, if the estimated TTC Thresold(s) is less than the configured time, no alarm is triggered.

**Audio Switch:** When set to On, there will be audio warning if an alarm is triggered, set to Off, no audio warning if an alarm is triggered.

**AlarmOut:** Level output switch. When enabled, Alarm 5 (Out) will output a high level signal when an alarm is triggered.

**Advance:** Advanced configuration options, the configuration interfaces for each alarm are shown below:

## ADAS CONTINUED...

FCW: Forward Collision Warning.

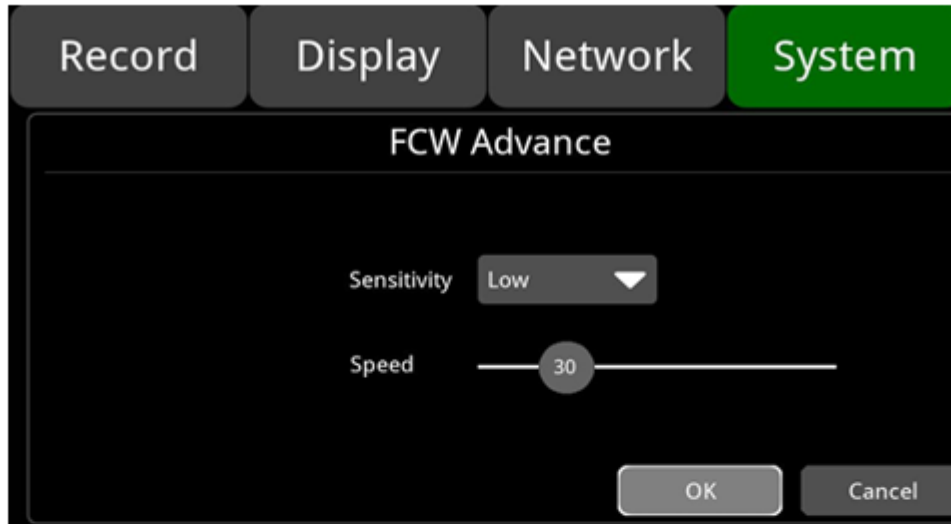

**Sensitivity:** There are three levels of sensitivity, Low, Medium, High, it is set to low by default.

**Speed:** If FCW working speed is set to 5, the FCW algorithm can be enabled only when the vehicle drives at or faster than 5km/h. FCW working speed is set to 30 by default.

PCW: Pedestrian Collision Warning.

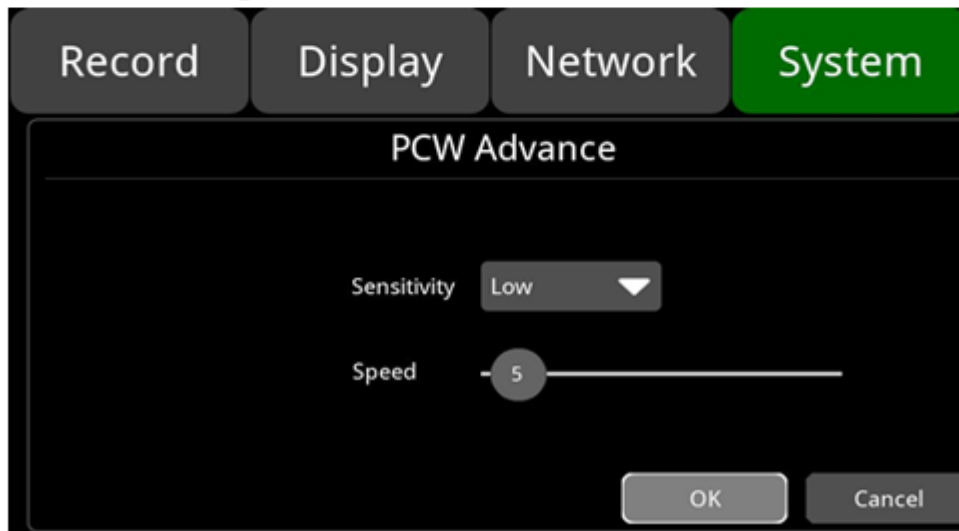

**Sensitivity:** There are three levels of sensitivity, Low, Medium, High, it is set to low by default.

**Speed:** If PCW working speed is set to 5, the FCW algorithm can be enabled only when the vehicle drives at or faster than 5km/h. FCW working speed is set to 5 by default.

## ADAS CONTINUED...

**LDWS:** Lane Departure Warning System.

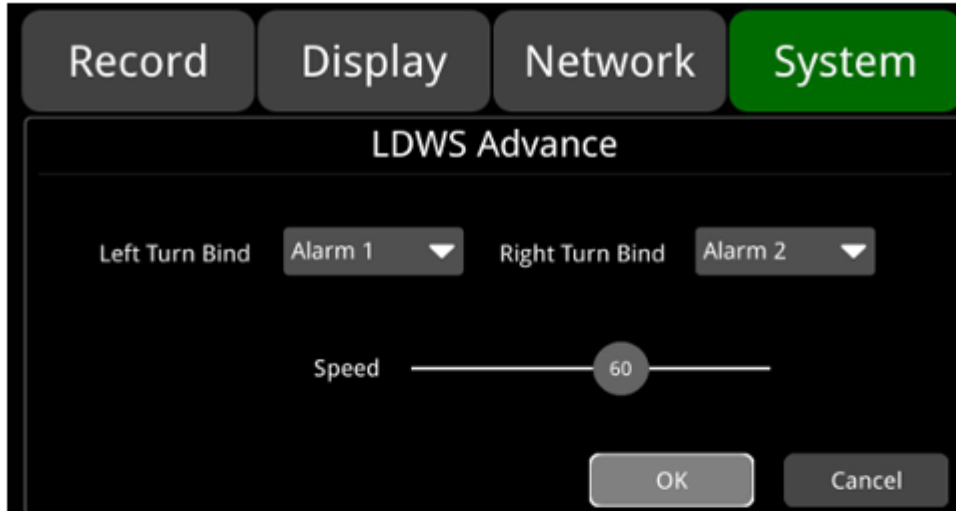

**Left/Right Turn Bind:** If the corresponding trigger wire of Left/Right Turn Bind is triggered during driving, the LDWS algorithm will not take effect. Left Turn Bind is set to trigger wire 1, and the Right Turn Bind is set to trigger wire 2 by default.

**Speed:** If LDWS working speed is set to 5, the LDWS algorithm can be enabled only when the vehicle drives at or faster than 5km/h. LDWS working speed is set to 60 by default.

**HWM:** Headway Monitoring Warning.

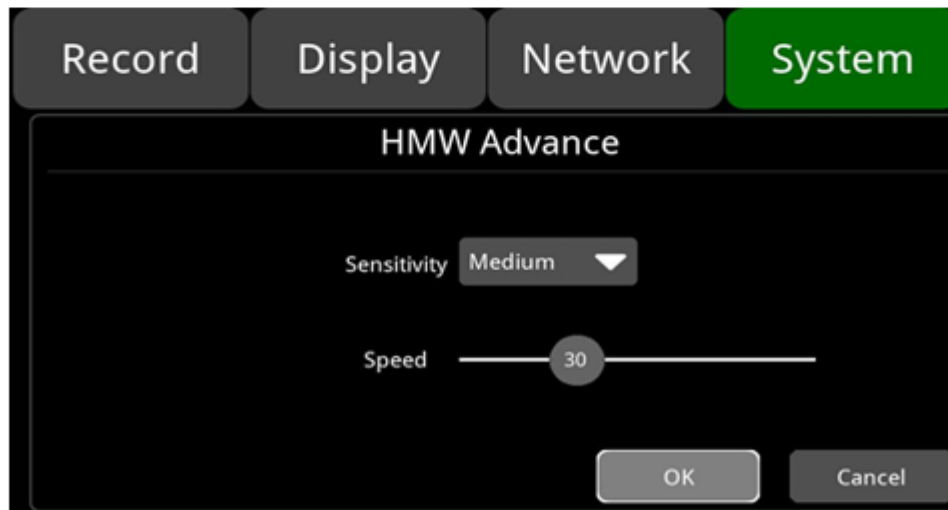

**Sensitivity:** There are three levels of sensitivity, Low, Medium, High, it is set to low by default.

**Speed:** If HWM working speed is set to 5, the HWM algorithm can be enabled only when the vehicle drives at or faster than 5km/h. HWM working speed is set to 30 by default.

**FrontCarStart:** Front Car Start Warning.

## DMS

**DMS Algorithm:** Detect and warn drivers of unusual behavior: driving fatigue, distraction, phone calling, smoking, hands off the wheel, not wearing a mask. No detection option is selected by default, you can manually enable the options. The following is the default configuration interface:

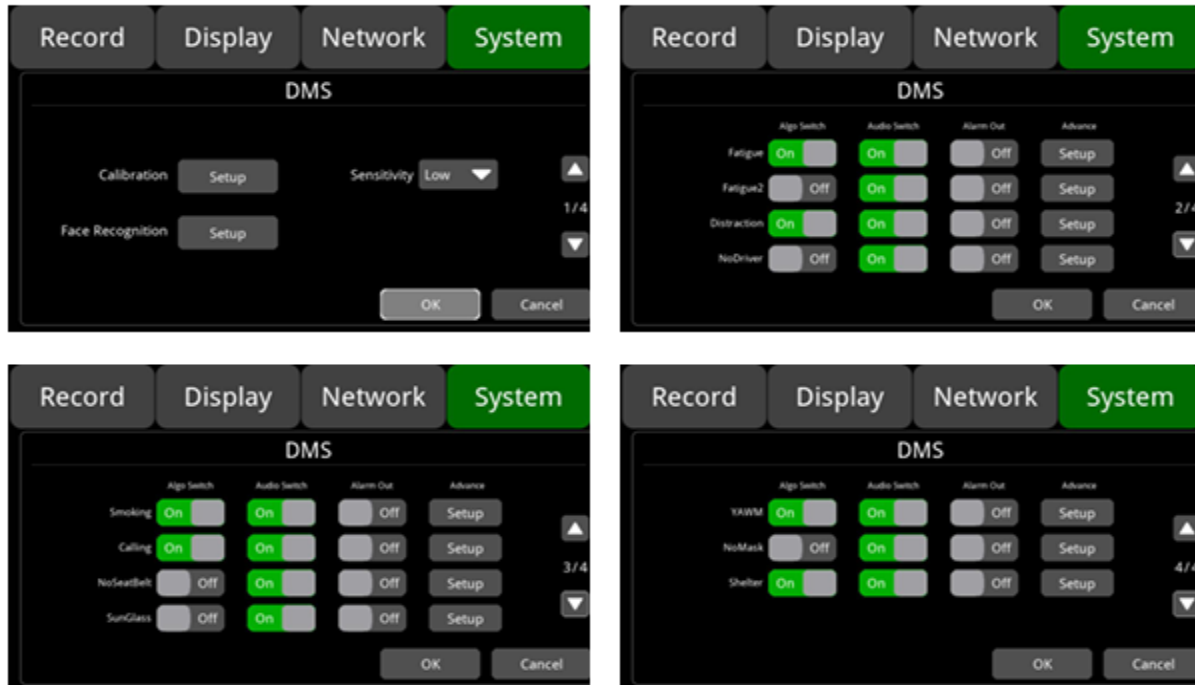

**Calibration:** Parameter calibration. The calibration box is blue by default, face to it and a green box will show. Click Start and after 2-3s, there will be a pop-up window with a voice prompt indicating successful calibration. Click the pop-up window to exit the calibration interface. As shown below:

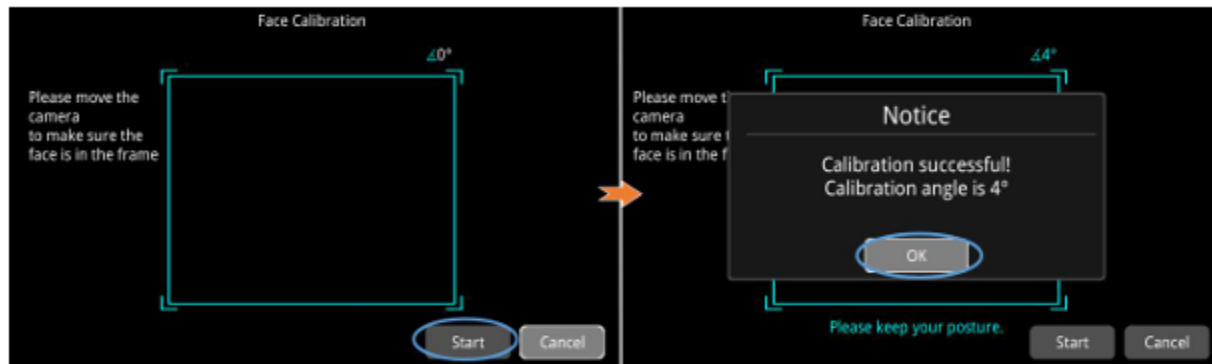

Face to the camera and ensure your face image is circled by the calibration box and click Start for calibration. During the calibration, if move your face out from the calibration box and the calibration box will turn yellow, and after 2-3s, a box will pop up indicating calibration failure, click the icon in the box then you can calibrate again. As shown below:



## DMS CONTINUED...

Face to the camera and ensure your face image is circled by the calibration box and click Start for calibration. If move your face right or left over 30 degrees, the calibration box will turn red with a voice prompt as "too left" or "too right", and after 2-3s, a box will pop up indicating calibration failure, click the icon in the box then you can calibrate again. As shown below:



When the calibration fails, click Start to calibrate again.

**Sensitivity:** There are three levels of sensitivity, Low, Medium, High, it is set to low by default.



+: Add a face, as shown in the picture below. Input the name and click OK. Face to the camera and click Start, turn the face up and down, left and right, then your face image is input into the device, a pop-up box will show to notice successful or failed calibration with a voice notice also.



:Delete function, as shown in the following picture, select the input face photo, click to delete it.

**Login:** Click to log in by face recognition.

**Login Check:** Set to On, each boot-up will start face recognition with a voice prompt "again to login", face to the camera, there will be a login success prompt; If your face is not detected or not input into the system before, there will be a login fail prompt. You will only receive the prompt once upon each startup. Set to Off, boot-up will not start the face recognition. It is set to Off by default.

**Algo Switch:** DMS alarm type switch and default configuration.

**Audio Switch:** Alarm audio switch, set to On, alarms will trigger voice prompt; set to Off, no voice prompt.

**Alarm Out:** Level output switch. When enabled, Alarm 5 (Out) will output a high level signal when an alarm is triggered.

**Alarm Out:** Level output switch. When enabled, Alarm 5 (Out) will output a high level signal when an alarm is triggered.

**Advance:** The startup speed of the algorithm can be set. It is set to 0 by default. The algorithm will be enabled when the startup speed is greater than the preset speed.

## DMS CONTINUED...

Alarm Type	Function Description	Function Description
DMS_Fatigue	DMS_Fatigue is On, when the driver's fatigue behavior is detected, the alarm recording will be triggered also with audio announcement.	DMS Fatigue is Off, fatigue alarm will not be triggered
DMS_Fatigue2	DMS_Fatigue2 is On, when driver's eyes-closing is detected after fatigue warning, the alarm recording will be triggered also with quick "didi" audio announcement.	DMS_Fatigue2 is Off, the second time fatigue behavior alarm will not be triggered.
DMS_Distractio	DMS_Distractio is On, when the driver's distraction behavior is detected, the alarm recording will be triggered also with audio announcement.	DMS_Distractio is Off, distraction alarm will not be triggered.
DMS_NoDriver	DMS_NoDriver is On, when driver's leaving seat during driving is detected, the alarm recording will be triggered also with audio announcement.	DMS_NoDriver is Off, leaving seat alarm will not be triggered.
DMS_Smoking	DMS_Smoking is On, when the driver's smoking is detected, the alarm recording will be triggered also with audio announcement.	DMS_Smoking is Off, smoking alarm will not be triggered.
DMS_Calling	DMS_Calling is On, when the driver's phone calling is detected, the alarm recording will be triggered also with audio announcement.	DMS_Calling is Off, phone calling alarm will not be triggered.
DMS_NoSeatBelt	DMS_NoSeatBelt is On, when the driver is detected with no seatbelt, the alarm recording will be triggered also with audio announcement.	DMS_NoSeatBelt is Off, not wearing seat belt alarm will not be triggered.
DMS_SunGlass	DMS_SunGlass is On, when the driver is detected with sunglasses, the alarm recording will be triggered also with audio announcement.	DMS_SunGlass is Off, wearing sunglasses alarm will not be triggered.
DMS_YAWN	DMS_YAWN is On, when the driver's yawning is detected, the alarm recording will be triggered also with audio announcement.	DMS_YAWN is Off, yawning alarm will not be triggered.
DMS_NoMask	DMS_NoMask is On, when the driver's not wearing mask is detected, the alarm recording will be triggered also with audio announcement.	DMS_NoMask is Off, not wearing mask alarm will not be triggered.
DMS_Shelter	DMS_Shelter is On, when camera is detected as sheltered, the alarm recording will be triggered also with audio announcement.	DMS_Shelter is Off, camera sheltering alarm will not be triggered.
Speed(km/h)	DMS working speed, when it is set to 30, the DMS algorithm will work only when driving at or faster than 30km/h. Working speed of each algorithm can be set separately.	

## DMS CONTINUED...

The default setting of DMS parameters are as follows:

Alarm Type	Default Setting
DMS_Fatigue	On
DMS_Fatigue2	Off
DMS_Distracton	On
DMS_NoDriver	Off
DMS_Smoking	On
DMS_Calling	On
DMS_NOSeatBelt	Off
DMS_SunGlass	Off
DMS_YAWN	On
DMS_NoMask	Off
DMS_Shelter	On
Sensitivity	Low
AudioSwitch	On

**DMS CONTINUED...**

Function	Alarm Duration / Interval	Minimum	Maximum	Default Value
Fatigue	Time(s)	1	6	3
	Interval Time(s)	0	300	3
	Threshold	1	99	45
Fatigue2	Time(s)	1	6	3
	Interval Time(s)	0	300	3
	Threshold	1	99	30
Distraction	Time(s)	1	9	5
	Interval Time(s)	0	300	5
	Threshold	1	74	35
NoDriver	Time(s)	1	30	15
	Interval Time(s)	0	300	15
	Threshold	/	/	/
Smoking	Time(s)	1	5	2
	Interval Time(s)	0	300	2
	Threshold	1	99	35
Calling	Time(s)	1	5	3
	Interval Time(s)	0	300	3
	Threshold	1	99	60
NoSeatBelt	Time(s)	1	20	10
	Interval Time(s)	0	300	10
	Threshold	1	99	25
SunGlass	Time(s)	1	30	10
	Interval Time(s)	0	300	5
	Threshold	/	/	/
YAWN	Time(s)	1	5	3
	Interval Time(s)	0	300	2
	Threshold	/	/	/
NoMask	Time(s)	1	15	0
	Interval Time(s)	0	300	10
	Threshold	/	/	/
Shelter	Time(s)	1	15	0
	Interval Time(s)	0	300	10
	Threshold	/	/	/

## BSD

**BSD Algorithm:** A high-definition camera with BSD function can detect pedestrians on the side and rear of the vehicle in real time, avoiding accidents caused by visual blindspots, is an essential driving safety assistance system for large vehicles such as trucks, buses, and engineering vehicles.

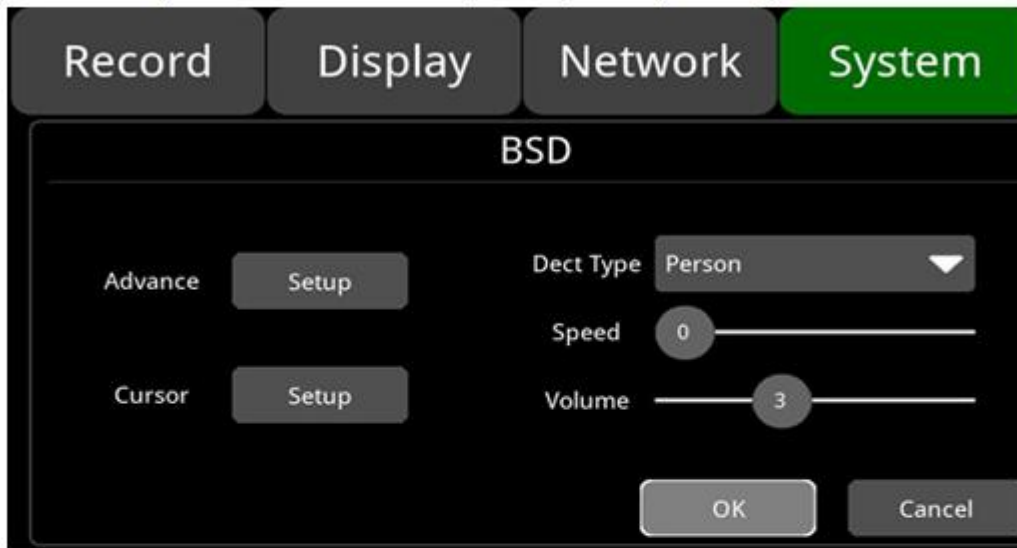

**Advance:** Set the BSD algorithm range and related alarm settings, as shown below:



**Audio Switch:** Set audio switch to On, there is audio warning output, no when set to Off. It is set to on by default.

**Algo Switch:** Algo Switch is to turn on/off the detection in three alarm areas. There are red, yellow, and green switches available. The red area is turned on by default.

**Alarm Out:** Level output switch. When enabled, Alarm 5 (Out) will output a high level signal when an alarm is triggered.

**Speed:** BSD working speed. The BSD algorithm can work only when the walking speed of a person is within the set range from 0 ~ 40.

**Volume:** Not supported.

**Threshold:** Pedestrian detection alarm accuracy.

## BSD CONTINUED...

	Minimum	Maximum	Default
Speed	0	100	0
Volume	0	8	3
Accuracy	50	99	63

**Threshold:** Pedestrian detection alarm accuracy.

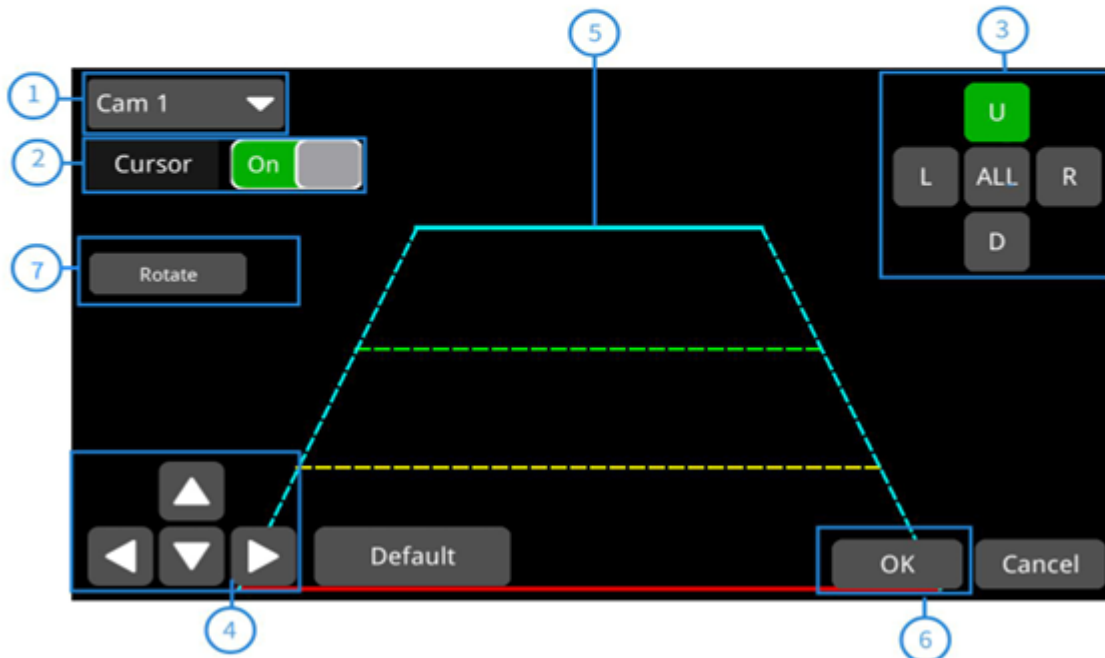

- ① Channel selection: Select the corresponding channel. The default channel is channel 1
- ② Click the switch to enable and disable the cursor of the corresponding channel
- ③ Line selection: up, down, left, right, all; icons in green show current status, you can press "1, 2, 3, 4, 5" in the remote for quick selection;
- ④ Click up, down, left and right to move the selected line
  - Select the line on the top: press left, right, up and down to move the green line;
  - Select the line on the left: press up and down to move the vertex of the left line to the right and left; press left and right to move the bottom point of the blue line left and right;
  - Select the line on the right: press up and down to move the vertex of the right line right and left; press left and right to move the bottom point of the right line left and right;
  - Select the line on the bottom: press left, right, up and down to move the bottom red line;
  - Select All: press left, right, up and down to move all the lines as a whole;
- ⑤ Cursor line: when selected, lines will be three times bold, except for the middle two lines
- ⑥ Click OK to save current settings. Clicking Cancel will still remain configuration of the last time.
- ⑦ Rotate: Cursor rotation

**Dect Type:** Detection types can be manually set, including pedestrian detection, vehicle detection and human&vehicle detection. It is set to pedestrian detection by default.

## APC

**APC Algorithm:** Passenger counting: count passengers getting on and off, and the total people on the vehicle. The following is the default configuration interface:



**Reset:** Click to return to previous settings

**Default:** Click to restore the default settings

**Counting Style:** Select the yellow line in the detection box to detect passenger getting on and off. If "Horizontal" is selected, it is then set to be a horizontal line that detects passengers getting on and off from up-down direction within the detection box. Similarly, if Vertical is selected, it is then set to be a vertical line for passengers getting on and off the vehicle from left-right direction.

**Counting Style:** Select the yellow line in the detection box to detect passenger getting on and off. If "Horizontal" is selected, it is then set to be a horizontal line that detects passengers getting on and off from up-down direction within the detection box. Similarly, if Vertical is selected, it is then set to be a vertical line for passengers getting on and off the vehicle from left-right direction.

**Direction:** Choose the direction of passenger detected getting on and off

**X0:** Adjust the left line position. Click "-" to move left and "+" to move right. The default value is 0.2

**Y0:** Adjust the top line position. Click "-" to move up and "+" to move down. The default value is 0.2

**X1:** Adjust the right line position. Click "-" to move left and "+" to move right. The default value is 0.8

**Y1:** Adjust the bottom line position. Click "-" to move up and "+" to move down. The default value is 0.8

## PRECAUTIONS

### ► Storage and Keeping

- Do not expose the monitor to excessive heat or cold. The storage temperature of this device is  $-30 \sim +80^{\circ}\text{C}$ , and the operating temperature is  $-20 \sim +70^{\circ}\text{C}$ .
- Never use this device near a bathtub, wash basin, kitchen, damp basement, swimming pool or similar places.
- Never use this device in the environment with excessive moisture, dust or smoke
- Avoid dropping or striking this device
- Avoid using this device in enclosed spaces, areas with excessive vibration or subject to severe impacts
- Never puncture, scratch or use abrasive cleaning materials on this device
- Do not place cables where they may be pinched or stepped on
- Leave at least a 2" space between the monitor and walls, cabinets or other objects to allow adequate air circulation around the device
- The monitor is not designed to be waterproof

### ► Operating Precautions

- The device can be powered by DC power 10V - 32V (e.g. 12V or 24V ACC)
- Make sure all cables are connected properly, and check the polarity, as improper cable connections may damage the monitor. Remove the power cable connections when you do not intend to use the device

## WARNING!

- High voltage is present within the monitor. The opening of the case should be by professionals
- Do not watch the video while driving unless you are monitoring the display

## SPECIAL NOTICE

Occasionally, a few highlights or dark spots may occur on the LCD screen. This is a very common phenomenon in active matrix display technology, and doesn't necessarily indicate any defects or faults

Never try to repair this device by yourself. In case of any problems, please turn off the display at once and notify our company or the authorized dealer. The monitor is a complex device, and any disassembly or modification may lead to damage and void the warranty.

## MAINTENANCE

- Remove all the cable connections from the monitor before cleaning the device.
- Use a mild household detergent and clean the unit with a slightly damp, soft cloth.
- Never use strong solvents such as thinner or benzine, as they might damage the finish of the device



### **CAUTION!!!**

**Risk of Electrical Shock  
DO NOT OPEN**



Caution: to reduce the risk of electric shock, Do not remove cover (or back).  
No user-serviceable parts inside.  
Refer servicing to qualified service personnel

You are cautioned that any changes or modifications not expressly approved in this manual could void your warranty and necessitate expensive repairs

### **[FCC COMPLIANCE STATEMENT]**

- This device complies with Part 15 of the FCC Rules. Operation is subject to the following two conditions:
  - This device may not cause harmful interference
  - This device must accept any interference received, including interference that may cause undesired operation